



## Part 2 – TECHNICAL REGULATIONS 2026

Name of the Series:  
**Porsche Sprint Challenge Benelux**

**Status of the Series/Events: National**

### Foreword:

CUP CHALLENGE BENELUX B.V., hereinafter called the Series Organizer, is hosting the Porsche Sprint Challenge Benelux for 2026.

Organisation	Cup Challenge Benelux B.V. Maastricht Randwyck Robert Schumandomein 2 resiresi 6226 ES Maastricht The Netherlands T+31 (0)43 790 1000 Licence number: KNAF 323
Contact	Lars Plato – Series Manager Mobile: +32 11 93 61 46 E-Mail: <a href="mailto:lars.plato@prospeed.be">lars.plato@prospeed.be</a> Home page: <a href="http://www.sprintchallengebenelux.com">www.sprintchallengebenelux.com</a>

## Table of Content

1.	Foreword .....	10
2.	Chapter subdivisions .....	10
3.	Source of .....	10
4.	Definitions .....	10
5.	Part numbers Porsche .....	11
<b>Part A.:</b>	<b>General Technical Regulations.....</b>	<b>11</b>
6.	General .....	11
7.	Pre-Event Scrutineering .....	12
8.	Parc Fermé.....	12
8.1.	SD cards during Parc Fermé.....	13
9.	Responsibility warning.....	13
10.	Accepted Cars and Divisions.....	13
11.	Exclusion of a Porsche Race Car .....	13
12.	Car Identity Passport.....	14
13.	Drivers safety equipment.....	14
13.1.	Drivers must wear the following items: .....	14
13.2.	Frontal Head Restraint System (FHR or comparable system) .....	14
13.3.	Drinking system .....	14
13.4.	Cooling system .....	14
14.	Car sticker regulations .....	15
14.1.	Sticker layout and Advertising on the Drivers' equipment, car and start numbers.....	15
14.2.	Advertising.....	15
14.3.	Exclusivity rule .....	16
14.4.	Contravention of these regulations.....	16
15.	Racing suit badge regulations .....	16
16.	Noise regulations .....	16
16.1.	Exhaust system .....	16
17.	Emission regulations .....	16
18.	Radio, data, transponder, camera.....	17
18.1.	Radio system.....	17
18.2.	Data recording .....	17
18.3.	Data Offload .....	17
18.4.	Timing Transponder .....	17
18.5.	Cameras .....	17
19.	Tyres & wheels.....	18
19.1.	Tyre types .....	18
19.2.	Sessions / Tyre quota .....	18
19.3.	Registration .....	18
19.4.	Treatment.....	18
19.5.	Tyre damages.....	18

19.6.	Exceeding the tyre quota .....	18
19.7.	Driver Swap .....	19
19.8.	Guest Drivers .....	19
19.9.	Recap table .....	19
19.10.	Tyre/rim sizes .....	19
20.	Electronic control units .....	19
21.	Fuel .....	19
21.1.	FIA FT3 Fuel tank.....	20
22.	Fire extinguisher .....	20
23.	General safety.....	20
23.1.	Safety stands.....	20
23.2.	Compressed air equipment .....	20
23.3.	Fire prevention .....	20
24.	Minimum Car weight .....	20
24.1.	Weighing of Cars .....	20
24.2.	Leaving the weighing area.....	20
24.3.	Replacement and loss of Car parts .....	21
24.4.	Parc Fermé rules for Car weighing.....	21
24.5.	Weighing in below the minimum weight .....	21
24.6.	Bringing the Car to the weighing area .....	21
24.7.	Minimum Car weight per Car type .....	21
24.8.	Ballast .....	21
25.	Ground clearance of Car.....	21
25.1.	Measuring method.....	21
26.	Seals.....	22
27.	Penalty for not being compliant with the Technical Regulations.....	22
27.1.	Penalty 1 .....	22
27.2.	Penalty 2 .....	22
27.3.	Violation resulting in Penalty 1 & 2 .....	22
27.4.	Other violations .....	22
<b>Part B:</b>	<b>Appendices .....</b>	<b>23</b>
28.	Table 1 - Tyre/rim sizes .....	23
29.	Table 2 – Minimum Car weight per Car type .....	24
30.	Table 3 – Ground Clearance .....	24
31.	Table 4 - max. permissible thicknesses of the spacer washers .....	24
<b>Part C:</b>	<b>Specific Technical Descriptions .....</b>	<b>25</b>
<b>Part C1:</b>	<b>Specific Technical Regulations according to model year Porsche GT3 Cup, Type 992 (MY'21-'25) 25</b>	
32.	General Car description.....	25
33.	Engine .....	25
33.1.	General description.....	25

33.2.	Cooling system:.....	25
34.	Power transmission (gearbox/differential lock) .....	25
34.1.	General description.....	25
34.2.	Ramp breakover angle .....	26
35.	Engine oil quick refill .....	26
36.	Brakes .....	26
36.1.	General description.....	26
37.	ABS System .....	26
38.	Wheel suspension .....	27
38.1.	General description front axle.....	27
38.2.	General description rear axle .....	27
38.3.	Anti-roll bars .....	27
38.4.	Shock absorbers/springs .....	27
39.	Wheels .....	28
40.	Bodywork and dimensions .....	28
40.1.	General description.....	28
40.2.	Lightweight exterior:.....	28
40.3.	Modified 911 cockpit: .....	28
40.4.	Water-based paint: .....	28
40.5.	Overall Car dimensions and overhangs: .....	29
40.6.	External bodywork (including windows) .....	29
40.7.	Cockpit.....	29
40.8.	Roll cage safety padding .....	30
40.9.	Additional roof hatch accessories .....	30
41.	Aerodynamic devices .....	30
42.	Electrical equipment .....	30
42.1.	General description.....	30
42.2.	LED Lighting system: .....	31
42.3.	Optionally, the usage of the following electrical equipment is permitted:.....	31
43.	Fuel circuit .....	31
44.	Lubrication system.....	31
44.1.	Lubricants .....	31
	Attachment 1: Ballast weights .....	32
	Attachment 2: Differential lock ramp breakover angle .....	33
	Attachment 3: Differential design.....	33
	Attachment 4: Seat .....	34
	Attachment 5: Timing transponder (Mandatory for all competing Cars).....	34
	Attachment 6: Ride height measuring positions .....	35
	<b>Part C2: Specific Technical Regulations according to model year Porsche 911 GT3 Cup, Type 991, Gen II ('17 – '19) .....</b>	<b>36</b>
45.	General information .....	36

46.	General Car description.....	36
47.	Engine .....	36
48.	Power transmission (gearbox/differential lock) .....	36
48.1.	Ramp breakover angle .....	36
48.2.	Transmission emergency function.....	37
49.	Brakes .....	37
50.	Steering (steering wheel/hub extension) .....	37
51.	Wheel suspension .....	38
51.1.	General description front axle.....	38
51.2.	General description rear axle .....	38
51.3.	Trailing arm.....	38
51.4.	Anti-roll bars .....	38
51.5.	Shock absorbers/springs .....	38
52.	Bodywork.....	39
52.1.	General description.....	39
52.2.	Lightweight exterior.....	39
52.3.	Modified 911 cockpit: .....	39
52.4.	Water-based paint: .....	39
53.	Overall Car dimensions and overhangs .....	39
54.	External bodywork.....	40
54.1.	Windscreen .....	40
54.2.	Side and rear windows.....	40
55.	Cockpit.....	40
55.1.	Safety Nets:.....	40
55.2.	Seat:.....	40
55.3.	Roll cage safety padding .....	40
55.4.	Additional roof hatch accessories .....	41
56.	Aerodynamic devices .....	41
57.	Electrical equipment .....	41
57.1.	General description.....	41
57.2.	Lighting system .....	41
58.	Fuel circuit .....	41
59.	Optional parts .....	42
60.	Lubrication system .....	42
61.	Fender guide plates.....	42
62.	Additional radiator protection .....	42
63.	Safety Nets.....	42
<b>Part C3: Specific Technical Regulations according to model year Porsche 911 GT3 Cup, Type 991, Gen I ('13 – '16) .....</b>		
64.	General information .....	44
65.	General Car description.....	44

66.	Engine .....	44
67.	Power transmission (gearbox/differential lock) .....	44
67.1.	Ramp breakover angle .....	44
67.2.	Transmission emergency function.....	45
68.	Brakes .....	45
69.	Steering (steering wheel/hub extension) .....	46
70.	Wheel suspension .....	46
70.1.	General description front axle.....	46
70.2.	General description rear axle .....	46
70.3.	Trailing arm.....	46
70.4.	Anti-roll bars .....	46
70.5.	Tie rods .....	46
70.6.	Shock absorbers/springs .....	47
71.	Bodywork.....	47
71.1.	General description.....	47
71.2.	Bodyshell protection .....	47
71.3.	Lightweight exterior equipment.....	47
71.4.	Modified 911 cockpit .....	48
71.5.	Water-based paint .....	48
72.	Overall Car dimensions and overhangs .....	48
73.	External bodywork (including windows) .....	48
73.1.	Windscreen.....	48
73.2.	Side and rear windows.....	48
74.	Cockpit.....	48
74.1.	Seat.....	48
74.2.	Safety Nets.....	49
74.3.	Roll cage safety padding .....	49
74.4.	Additional roof hatch accessories .....	50
75.	Aerodynamic devices .....	50
76.	Electrical equipment .....	50
76.1.	General description.....	50
76.2.	Lighting system .....	50
76.3.	Filter cable .....	50
76.4.	Fire extinguisher system .....	51
77.	Fuel circuit .....	51
78.	Optional parts .....	51
79.	Lubrication system.....	51
<b>Part C4: Specific Tech. Regulation according to the Porsche 718 Cayman GT4 RS Clubsport (MY 2021 – 2024)</b>		
80.	General information .....	51
81.	Engine .....	51

81.1.	Engine electronic control units.....	51
82.	Exhaust system .....	52
82.1.	General description.....	52
82.2.	Exception .....	52
83.	Power transmission (Gearbox/Differential Lock) .....	52
84.	Lubrication system.....	52
85.	Brakes.....	52
85.1.	General description.....	52
86.	Wheel Suspension.....	53
86.1.	General description front axle.....	53
86.2.	General description rear axle .....	53
86.3.	Allowed adjustments .....	53
86.4.	Anti-roll bars .....	53
86.5.	Shock absorbers/springs .....	53
87.	Ballast .....	54
88.	Bodywork and dimensions.....	54
88.1.	General description.....	54
88.2.	Overall car dimensions and overhangs:.....	54
88.3.	External bodywork (including windows) .....	54
88.4.	Windscreen .....	54
88.5.	Rear window.....	55
89.	Cockpit.....	55
89.1.	Seat.....	55
89.2.	Safety nets .....	55
89.3.	Additional roof hatch accessories .....	55
90.	Aerodynamic Devices.....	55
91.	Electrical equipment .....	55
91.1.	General description.....	55
92.	Fuel Circuit.....	56
92.1.	'Trophy' specifications tank plate (fuel gun) .....	56
	Attachment 1: Ballast weights .....	57
	Attachment 2: Minimum Ground Clearance GT4 RS Clubsport.....	58
	Attachment 3: Seat Padding .....	59
	Attachment 4: Extra silencers. ....	59
	<b>Part C5: Specific Tech. Regulation according to the model Porsche 718 Cayman GT4 MR Clubsport, Type 982, ('19-'20).....</b>	<b>60</b>
	<b>Part C6: Specific Tech. Regulation according to the model Porsche 718 Cayman GT4 Clubsport, 'Trophy'-spec, Type 982, ('19-'20) .....</b>	<b>60</b>
93.	General Car description.....	60
94.	Engine .....	60
95.	Power transmission (gearbox/differential lock) .....	60

96.	Brakes .....	61
97.	Steering (steering wheel/hub extension) .....	61
98.	Wheel suspension .....	61
98.1.	General description front axle.....	61
98.2.	General description rear axle .....	61
98.3.	Wheelbase .....	61
98.4.	Anti-roll bars .....	61
98.5.	Shock absorbers/springs .....	62
99.	Bodywork.....	62
99.1.	General description.....	62
99.2.	External Bodywork (including Windows).....	62
99.3.	Cockpit.....	63
100.	Electrical Equipment .....	63
101.	Air Jack System .....	63
102.	Water-based paint .....	63
103.	Overall Car dimensions and overhangs .....	63
104.	Lubrication system.....	64
105.	Fuel system.....	64
105.1.	'Trophy' specifications tank plate (fuel gun) .....	64
106.	Mandatory rework.....	64
106.1.	Engine air ducts mesh: .....	64
106.2.	Safety nets: .....	64
106.3.	Safety foam Driver's door: .....	64
106.4.	Brake pressure switch:.....	64
106.5.	Roll over valve .....	65
<b>Part C7: Specific Tech. Regulation according to the model Porsche Cayman GT4 Clubsport, 'Trophy'-spec, Type 981, ('16).....</b>		
107.	General Car description.....	65
108.	Engine .....	65
109.	Power transmission (gearbox/differential lock) .....	65
110.	Brakes .....	65
111.	Steering (steering wheel/hub extension) .....	66
112.	Wheel suspension .....	66
112.1.	General description front axle.....	66
112.2.	General description rear axle .....	66
112.3.	Wheelbase: .....	66
112.4.	Anti-roll bars .....	66
112.5.	Shock absorbers/springs .....	66
113.	Bodywork.....	67
113.1.	General description.....	67
113.2.	External Bodywork (including Windows).....	67

113.3.	Cockpit.....	68
113.4.	Seat, seat console Porsche Cayman GT4 CS (Type 981 and Type 982) .....	68
114.	Additional Accessories .....	68
114.1.	Underbody.....	68
114.2.	Engine cover: .....	68
114.3.	Engine Air Ducts.....	68
114.4.	Aerodynamic Devices.....	68
114.5.	Safety nets: .....	68
114.6.	Driveshaft flange spacer: .....	69
115.	Electrical Equipment .....	69
116.	Air Jack System .....	69
117.	Water-based paint: .....	69
118.	Overall Car dimensions and overhangs: .....	69
119.	Lubrication system .....	69
120.	Fuel system .....	69
120.1.	‘Trophy’ specifications (refuelling with fuel gun) .....	70
120.2.	Rollover valve: .....	70

## 1. **Foreword**

The Porsche Sprint Challenge Benelux (PSCB) is a series that focuses on the gentleman driver and drivers with prior track day experience. The series gives the competitors the opportunity to compete with Porsche 911 GT3 Cup models and Porsche Cayman GT4 Clubsport models built in the years as specified. All cars need to be in the specification such as they left the factory, except when this is clearly allowed by these regulations. If at any time a team is in doubt about their car's legality, either because of aftermarket modifications made to the car in its history or because they have fitted original parts sold some time after the production of their specific car, then they are encouraged to have the car checked by the series' technical manager.

## 2. **Chapter subdivisions**

The hierarchy of the chapters is shown in the example underneath.

The regulations stipulated in Part A and B apply to all competing cars or are clearly indicated as an exception. Further in Part C are all the specific regulations mentioned per model group (911/Cayman). In some cases, as for the 991 another subchapter is created to indicate the technical rules per model year or generation.

992 must comply with PART A + PART B + PART C1

GT4 RS must comply with PART A + PART B + PART C4

## 3. **Source of Information**

### **Spare parts catalogues, Technical manuals, technical info's, software updates, etc:**

#### **Porsche:**

- PMRSI (motorsport.porsche.de)
- Porsche Centre
- Manthey Racing
- Further applications: [etienne.ploenes@prospeed.be](mailto:etienne.ploenes@prospeed.be),

#### **Sales Porsche Motorsport parts & Equipment:**

#### **Sales Manthey Racing Parts & Equipment:**

#### **Sales Porsche Series parts & Equipment:**

Prospeed Competition bvba  
Industrieweg 2050  
B-3520 Zonhoven  
Belgium  
[peter.reyniers@prospeed.be](mailto:peter.reyniers@prospeed.be) / [raceparts@prospeed.be](mailto:raceparts@prospeed.be)

#### **Official Michelin Tyre Supplier:**

Kronos Racing S.A.  
Rue des Pieds d'Alouettes 37  
B-5100 Naninne  
Belgium  
Charles-Antoine Hastir  
[charly@kronostyres.com](mailto:charly@kronostyres.com)  
+32 (0)479 97 15 14

## 4. **Definitions**

PSCB	Porsche Sprint Challenge Benelux as the series organizer.
TR	Technical regulations
Team	The entrant and entrant personnel
MY	Model year, indicates the model version
Gen I	Porsche GT3 Cup cars with model year 2013, 2014, 2015 and 2016
Gen II	Porsche GT3 Cup cars with model year 2017, 2018 and 2019
Gauge block	A calibrated tool with specific dimension, which is not variable.
PPN.	Porsche part number
MTHPN.	Manthey Racing part number
MR	Manthey Racing

## **5. Part numbers Porsche**

Part numbers are indicated by the abbreviation 'PN.'. Part numbers starting with 'MTH' refer to 'Manthey Racing' parts. Those parts can only be found in the Manthey Racing catalogue of the respective Car. Other part number not starting with 'MTH' are 'Porsche Motorsport' or 'Porsche Road' parts. In the Porsche Motorsport catalogue of the concerning Car is indicated if the part is a Motorsport or a road part. Components listed in the parts catalogue that have a predecessor may be used subject to approval by the scrutineers.

## **Part A.: General Technical Regulations**

In 'Part A Porsche Sprint Challenge Benelux General Technical Regulations' are the technical regulations described valid for all competing cars or mentioned otherwise in the specific regulations per class or per car type?

## **6. General**

Everything that is not expressly permitted in these regulations is prohibited. Permitted modifications must not result in any illegal modifications or infringements of the regulations. Any permitted changes may only serve the intended purpose. The decision of the series organizer shall be final regarding any interpretation of these regulations. The series organizer reserves the right to amend and extend these rules. Work may be carried out within the normal scope of car maintenance or for the purpose of replacing parts damaged as a result of wear or accidents. Modifications and built-in components are only allowed within the scope defined further in these Technical Regulations. Parts damaged as a result of wear or accidents may only be replaced by genuine parts that are dedicated to the eligible cars. The use of racing components manufactured by the designated manufacturer for other groups of cars (e.g., road cars) is prohibited. Standard fastening components on the complete car, such as nuts, bolts, washers, spring rings, spring washers, and split pins, may only be replaced by genuine parts. In the case of threads, the thread type, size, and pitch are to be retained. Only genuine spare parts must be used. This means it is not allowed to use identical parts from the same manufacturer without the PPN indication. If the entrant has doubts regarding any parts being original, the entrant must check this with the technical manager, but it is the responsibility of the entrant to only use original parts. Parts and the body shell must not be modified. In case of damage, the car must be repaired to its original state if a repair is permitted by the technical manager. The entrant who engages/signs up for the Porsche Sprint Challenge Benelux championship accepts and acknowledges these technical regulations. In any case, it is the responsibility of the entrant to be in accordance with these technical regulations.

The organization of the Porsche Sprint Challenge Benelux reserves the right to change the minimum car weight at any time. The organization also reserves the right to exclude or reject a car if the car type and/or performance doesn't fit in the global mindset or goal of the Porsche Sprint Challenge Benelux.

Should there be any discrepancy between the provisions of these technical regulations and any relevant technical manual, technical information, or parts catalogue, then these technical regulations will take precedence.

Any requirements specified in a technical manual, technical information, software versions, and/or parts catalog may be updated by Porsche AG. For software, only the latest version is valid. Setups (based on the latest version) may be varied within the parameters allowed by Porsche AG. Any requirements may be varied for any specific competition by means of a Stewards of the Event Bulletin issued at the event. It's the competitor's responsibility to ensure the latest software packages (Firmware/ Setup) are uploaded to the devices mounted in the cars within the competitor's responsibility. Also, it is his responsibility so set the date and time in the logger according to the correct local time.

The tools and/or measuring equipment used by the technical scrutineers during scrutineering are binding, and any appeal or prosecution against the tools/measurement equipment in any way is not permitted. As described further in these regulations, the entrant has the possibility to use the tools/measurement equipment of the organization to check his car if it is complying with these technical regulations. This way the entrant has the possibility to compare the measuring result, taken with the entrant's measuring equipment, with the results taken with the measuring equipment of the organization and adjust the car accordingly to these technical regulations.

The scales (used to weigh the cars, drivers, fuel, or parts) are included in the 'tools and measuring equipment' used by the scrutineer. Which means that any appeal or prosecution against the scales used by the scrutineer is not permitted.

At the start of the pre-event technical scrutineering, which means the technical scrutineering before the first qualifying session, the technical scrutineers and/or series organizer indicate to the entrant where the ground clearance and car weight will be measured. This can be done by mentioning it in the Supplementary Regulations, by bulletin, or in any other team info or verbal message. The ground clearance is measured on a surface indicated by the technical scrutineers and/or series organizer. This 'surface' can be a measuring plate, a surface exclusively designated for this purpose, or any other surface. This surface is the reference surface, and this surface is binding. Any appeal or prosecution against 'the reference surface' in any way, is not allowed.

In case of any discussion, unclear points, or lack of the technical regulations, the series manager, technical manager, and technical scrutineer of the event will decide on the matter. After this decision, a clarification or addition to the technical regulations will be converted into a bulletin to the technical regulations.

## **7. Pre-Event Scrutineering**

Before the start of each event, a pre-event scrutineering timetable will be made up. It is the team's (entrant's) responsibility to attend the scrutineering in time, at least 5 minutes in advance. If the competitor can't attend in time, the technical scrutineers must be informed before the start of the pre-event scrutineering session. If this isn't the case, a penalty will be decided by the stewards of the event. Per car, only 2 mechanics, 1 team manager, and the driver of the car are allowed in the scrutineering area. All persons whose car isn't scrutineered at the moment aren't allowed in the scrutineering area. The car will be checked on safety, documentation, additional ballast sealing, car layout, general conformity, and camera system.

The competitors need to present their cars in perfect condition. This means that the cars need to be clean, inside and outside. Damage from previous events will not be tolerated. Body parts must be repaired or changed before the pre-scrutineering if they were damaged during a previous event. Tape as a temporary repair solution on body parts will not be tolerated by the scrutineer during the pre-scrutineering. Stickers from other series on the outside of the car are prohibited. All black plastic body parts and grills may not be painted. Exception: the logo of the team can be painted in white on the central radiator grill. The rear wing and its side plates may be painted. Painting and covering any lights with colored tape or wrap is strictly prohibited. In short, the cars must be presented at the pre-scrutineering in the same grade of visual condition as they were delivered when they were new.

The team must take with them to the pre-event scrutineering:

- Porsche car (compliant with all valid regulations incl. stickers, camera system, ballast etc.)
- Documentation of the car:
  - Data sheet
  - Safety cage certificate
  - Fuel tank certificate
- Additional equipment:
  - Bottle of compressed air
  - Air lance
  - Safety system to put under the car
  - Wheel gun or torque wrench
  - Centre lock nut

## **8. Parc Fermé**

After the qualifying sessions and the race sessions, all cars need to go immediately to Parc Fermé. If Parc Fermé is closed, it will be indicated with a red flag. If Parc Fermé is open, it will be indicated by the red flag being removed. The flag will be shown in an easy-to-see spot location at Parc Fermé, at the PSCB spare parts truck, at the PSCB tent, in the pit lane, in the pit box, or elsewhere. This will be communicated in the supplementary regulations, bulletin, or any other team info or verbally. At least one team member must be present and available to the scrutineers at the outside borders of the Parc Fermé during the whole Parc Fermé period. The SD card of the car must be clearly identified with the car competition number and must be handed over to the technical scrutineer in the technical check area when the rules of Parc Fermé apply.

### 8.1. SD cards during Parc Fermé

During Parc Fermé, teams are allowed and obliged to retrieve the SD cards from the camera system to hand them over to the technical scrutineers or technical staff of PSCB. Copying or accessing the data of the SD cards during parc fermé conditions is prohibited.

## 9. Responsibility warning

In some cases, the Porsche Sprint Challenge Benelux organization tolerates modifications on the accepted race car. The modifications/exceptions are clearly written and indicated with the word 'Remark' in the Technical Regulations and only valid for a specific class or car type. If a subject is indicated with a 'Remark' and it is tolerated to use non-original parts, it is still strongly recommended to only use original parts found in the Spare Parts Catalogue of the eligible car.

- These modifications/exceptions could be additional genuine spare parts available for the eligible car that are prohibited in a regular Porsche One Make Series. The concerning parts are in the spare parts catalogue of the eligible car, indicated as an option.
- These modifications could be the use of consumables such as brake pads, brake discs, or fluids. Only parts original to the car type found in the spare parts catalogue of the eligible car have been tested for racing purposes. These modifications could decrease the reliability of the Porsche race car.
- Other tolerated modifications are described in these technical regulations.

Porsche AG, Porsche Sprint Challenge Benelux, Cup Challenge Benelux BV, or Prospeed Competition BV (Technical Support) can't be held responsible, in any case, for the failure of the race car and all the accompanying consequences. In all cases the entrant, including driver and team (in the broadest sense of the word), is fully responsible. Even for the tolerated exceptional modifications found in these regulations, the entrant is fully responsible at all times.

Cars of older model years, such as Porsche 911 GT3 Cup (type 991), can get dispensation for non-original parts, as not all parts may be available anymore. Dispensation will be granted by the series' technical manager, the series organizer, and the technical scrutineers.

## 10. Accepted Cars and Divisions

Class	Car Type	MY
GT3 CUP	Porsche 911 GT3 Cup, type 992 + ABS	'21-'25
	Porsche 911 GT3 Cup, type 991 Gen II + ABS	'17-'19'
	Porsche 911 GT3 Cup, type 991 Gen I + ABS	'13-'16
CAYMAN	Porsche 718 Cayman GT4 RS Clubsport, type 982	'22-'24
	Porsche 718 Cayman GT4 Clubsport MR, type 982 (with air intake)	'19-'20
	Porsche 718 Cayman GT4 Clubsport MR, type 982 (without air intake)	'19-'20
	Porsche 718 Cayman GT4 Clubsport, type 982 (Trophy spec)	'19-'20
	Porsche Cayman GT4 Clubsport, type 981	'16

The cars must meet these regulations (Part A and Part B) and the specific technical specifications of Part C and Appendix J of the FIA International Sporting Code in full. A change of cars must be applied for in writing by the team (entrant) and must be approved in written form by the series organizer prior to the change. The decision to approve a change of car is at the absolute discretion of the series organizer.

## 11. Exclusion of a Porsche Race Car

The PSCB has the right to exclude a car from competing during an event when the car isn't repaired correctly after an incident. It doesn't matter if this incident took place during a PSCB Event, unofficial test session or other championship events. The arguments could be:

- Safety, in the broadest sense of the word.
- Car is in violation with the technical regulations of the PSCB.
- Any reason that Porsche AG (in the broadest sense of the word) defines by any medium (verbally, phone call, email, letter etc.).

- Damaged or Repaired roll cage without 'Semcon' certificate.
- Damage to the car (reference: technical manual).
- Chassis marked as unrepairable in the Porsche Motorsport database.

Damaged structure is only apparent when a jig is fitted or by measuring check points on the chassis. Cast aluminium parts that show a deviation of +/- 2 mm are out of tolerance. The chassis must be replaced by a new one.

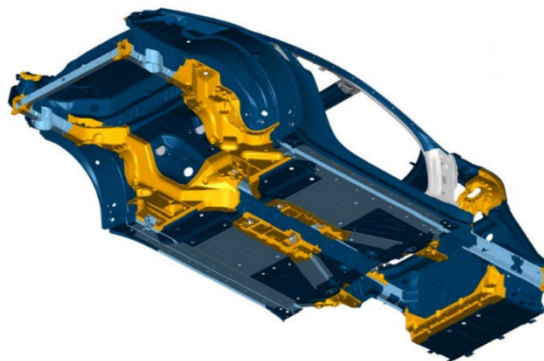

The CAD image shows the cast aluminium parts of the chassis.

The series technical manager always will, after consulting Porsche AG, make the final decision if a damaged chassis needs replacement or can be repaired. The series technical manager will supply the owner of the chassis and Porsche AG with a report regardless of the outcome of his decision.

These criteria apply to all cars in all divisions.

## **12. Car Identity Passport ("Datasheet")**

Technical passport: folder of the Car with registration documents of engine, gearbox, chassis, roll cage certificate and FT3 tank certificate (if applicable).

## **13. Drivers safety equipment**

### **13.1. Drivers must wear the following items:**

- Overalls in accordance with FIA Standard 8856-2000 or 8856-2018.
- Underwear (with long sleeves and pants) in accordance with FIA Standard 8856-2000 or 8856-2018.
- Balaclava in accordance with FIA Standard 8856-2000 or 8856-2018.
- Socks in accordance with FIA Standard 8856-2000 or 8856-2018.
- Shoes in accordance with FIA Standard 8856-2000 or 8856-2018.
- Gloves in accordance with FIA Standard 8856-2000 or 8856-2018.
- Helmet including FHR clips in accordance with FIA regulations (Appendix L to FIA ISC).  
must be always worn during practice, qualifying and races.

The Drivers' equipment must be checked by the scrutineer at the start of each event. The moment and location will be communicated in the supplementary regulations or the team info.

### **13.2. Frontal Head Restraint System (FHR or comparable system)**

The use of an FIA-approved head restraint in compliance with FIA list No. 29 is compulsory for all races and events within the championship as well as for all races outside the championship that are organized according to these regulations. Responsibility for the necessary modifications to the drivers' equipment in order to enable use of such a system and installation of same in the car in compliance with the manufacturer's instructions lies solely with the participant. The relevant manufacturer's certificate is to be presented during technical scrutineering.

### **13.3. Drinking system**

A drinking system with an electric pump may be used.

### **13.4. Cooling system**

A cooling system with cooling vest may be used.

## **14. Car sticker regulations**

### **14.1. Sticker layout and Advertising on the Drivers' equipment, car and start numbers**

The current FIA prescriptions for starting numbers and for advertising on the drivers' equipment/on the race car and start numbers must be respected.

The advertising decals, logos, driver name, and starting numbers, as specified by the series organizer, must be affixed to all competing cars during the qualifying sessions, and races of the series. The size, type, quantity, and positioning are determined and announced in the "PSCB Sticker Regulations 2026". Any breach of these regulations may result in the participant concerned being disqualified from classification. All advertising surfaces that are not occupied as specified in the Sticker Regulations are available for the entrants' own advertising labels.

The clearance between such advertising and the mandatory labels and starting number shall be a minimum of 30 mm retained for the entire season. The registered entrants will be informed about their starting numbers before the first race. The starting number markings must be fixed on all competition cars throughout the entire event. The size, type, quantity, and positioning of the identifications shall be determined by the Series Organizer, and notification is given in the "PSCB Sticker Regulations 2026". The team (entrant) is responsible for ensuring that the stickers on the entered cars comply with the applicable legal regulations.

All mandatory stickers are provided by the PSCB. Only this version of the mandatory stickers is allowed, copies of the mandatory stickers will be refused. It is forbidden to cut or to modify the dimensions of the received mandatory stickers. For example, the start number background can't be partly placed on the door and partly on the wing and cut in two. It's allowed to modify the dimensions of the window banner to avoid an overlay of the A-pillar and roof.

The mandatory window streamer is redeemable. The cost is 5000 EUR per car per season. The "PSCB Sticker Regulations 2026" will be announced before the start of the season.

### **14.2. Advertising**

Upon entering the PSCB, an entrant and the drivers acknowledge the sporting and technical regulations and thereby acknowledge that the organizer and its partners are granted the right to use all photo and video material produced during the events of the competitors for promotional or marketing purposes.

The use of the PSCB name and logo is forbidden without expressly written approval by the PSCB organization. Even with the organizers approval, the current Porsche Corporate Identity for Porsche racing as specified by Porsche AG must always be complied with. No marketing activities connecting to the championship may be deployed without cooperation with and approval by the PSCB organization.

All cars have to be presented in a presentable and representative state at the start of each event; see technical regulations. The organizer reserves the right to make mid-season changes to the corporate identity and logo layout.

Team trucks may carry the PSCB logo only in such a way as it is specified in the corporate identity specified by Porsche AG for racing. A sticker layout for trucks incorporating this corporate identity will be made available to the teams upon request. All digital artwork required to comply with the corporate identity will be delivered to teams at no cost by the organizer.

Any breach of the prescriptions will be seen as a direct violation of the regulations, and penalties will be applied as such, including and up to the loss of championship points or exclusion from an event. The Series organizer and PSCB sponsors shall acquire all rights to use sporting success for advertising purposes without paying separate fees for this purpose.

Teams must not enter into partnerships with companies that are either in competition with Porsche AG, its parent or partner companies, the official series partners of PSCB, or who are involved in a legal dispute with Porsche AG or a company associated with the manufacturers. PSCB is entitled to prohibit teams from entering into a partnership if the potential partner falls into one of the above categories.

The use of advertisements for companies, their products, services, or brands that are competitor products, services, or brands of Porsche AG, their associated companies, or the series sponsors on cars, helmets, race

suits, and other driver equipment, on team cars, or on team clothing, or any other kind of advertising for these companies, products, or services is strictly prohibited.

The use of advertisements for companies in the tobacco and sex industry, or political or religious advertising, or private betting and gambling operators on cars, helmets, race suits, and other driver equipment; on team cars; or on team clothing, or any kind of advertising for these companies, products, or services, or anything that may be deemed by Porsche AG to bring the series into disrepute is strictly prohibited. The advertising guidelines of the FIA and ASN, as well as general or legally regulated advertising bans, must be observed. The team (entrant) is obliged to notify the series organizer of all potential partners/sponsors. The PSCB is entitled to prohibit teams from displaying or promoting in any manner the details of any unapproved partners/sponsors.

Team partners/sponsors must be registered with the series organizer no later than 7 days before the start of an event. If team partners/sponsors are either registered late or not at all with the series organizer, then the entrant may be fined by the series organizer. The entrant and team partners/sponsors shall grant to the series organizer and the series sponsors all materials depicting the championship and/or rights to use sporting success for advertising purposes, without paying separate fees for this purpose.

#### **14.3. Exclusivity rule**

Team sponsors who are competitors of the official series partners of Porsche AG are not permitted under any circumstances. It is prohibited to communicate advertising on the Car for companies and products that are in competition with Porsche AG or its series and cooperation partners. With regard to the exclusivity of the series and cooperation partners of Porsche AG, the following rules apply (the exclusivity rule refers either to the industry sector or to the defined product range of the company):

1. 'Michelin' is the exclusive partner for the product area "Tyres". The teams are therefore prohibited from communicating advertising for companies and products that are in competition with 'Michelin' tyres.
2. In general, the following applies: No exemption is possible for partners of exclusivity category 1. For partners of exclusivity category 2, one release is possible on written request per product category and per team. The classification in exclusivity 1 and 2 will be defined individually per partner and is published in the separate list.

#### **14.4. Contravention of these regulations**

Contravention of any of the advertising regulations may result in a fine of at least EUR 1,000, and/or refusal to participate in any event or exclusion from the event, in each case at the discretion of the Stewards of the event.

#### **15. Racing suit badge regulations**

The mandatory logos and badges on the Drivers' racing overalls are described in "PSCB Badge Regulation 2026". This is part of these Regulations. Any breach of these Regulations may result in the participant concerned being disqualified from classification.

#### **16. Noise regulations**

Government environmental rules may override the noise regulations during an event. Pre-silencers (if applicable) are mandatory at all events.

The PSCB organisation is not responsible for any consequences for exceeding the noise limits imposed by the circuit or local ASN. For example, due to different measuring procedures or tolerances.

##### **16.1. Exhaust system**

Only original Porsche race exhausts are allowed. During all events the most 'silent' exhaust, including side mufflers, is mandatory. The parts required are listed in the currently valid parts catalogue and installation of these components is described in the technical manual.

A dispensation can be granted for non-original exhaust systems. These exhaust systems can be permitted to achieve lower noise levels of a car. The dispensation needs to be requested to the series organisation at least 3 days before the event. The dispensation is granted by the respective technical scrutineer.

#### **17. Emission regulations**

The current FIA emissions regulations are to be observed. The cars must be equipped with a catalytic converter in accordance with the FIA exhaust gas specifications as supplied by the respective manufacturer.

## **18. Radio, data, transponder, camera**

### **18.1. Radio system**

A radio system is allowed to fulfill the communication between the driver and team members. Make sure that the cable loom for the radio is properly fitted. The choice of hardware for radio reception from the “earplug” port to the driver is not specified but must be checked and approved by the technical scrutineers. When mounting fixed speakers in the driver's helmet, the FIA helmet regulations must be strictly observed. In the case of any ambiguity, the driver/entrant must show proof that the components used are suitable for use in the car (fire prevention etc.).

### **18.2. Data recording**

A data recording system is accepted. If the car was delivered from the factory with such a system, then the data recording system is compulsory. The use of other radio-based information transmission in the car (e. g. telemetry, video footage etc.) is forbidden.

### **18.3. Data Offload**

From the moment the car enters the track or pitlane to the end of the Parc Fermé during qualifying and racing, only the series organizer and personnel nominated by the series organizer are allowed to connect laptops/computers to the cars. The word ‘track’ is understood as the part of a circuit that is clearly demarcated for racing. For the same period, no external connection (also wireless) may be made between the car and any external equipment. It is not permitted at any time for any competitor to read any sensors with any equipment that is not allocated to the competitor's own team. Any breach of this regulation will be reported to the Stewards of the event. The PSCB technical manager or his representative always has the right to download any of the logged data in the car or to request previously downloaded data by the team.

### **18.4. Timing Transponder**

Each team must equip their Car with a AMB transponder, for example from Mylaps. When a car is shared by two drivers, it is mandatory to have a Driver-ID switch installed. The timing transponder must be mounted in the front right wheel arch behind the front axle as shown underneath. The illustration below refers to all cars. Consult the series technical manager or scrutineer if needed.

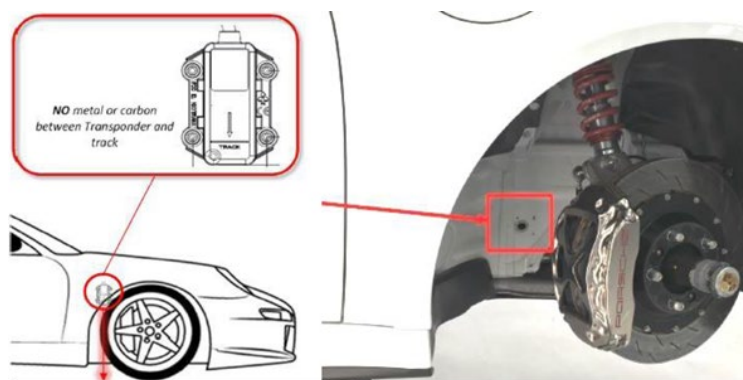

### **18.5. Cameras**

The installation of a camera system is mandatory. The system must record in ‘High Definition’ resolution. The system time and date of the camera system must be checked and adjusted according to the actual time zone in which the event is taking place. This installation will be checked by a member of the technical scrutineers. It is the responsibility of the competitor to provide the equipment. Each competitor needs to make sure each session is recorded and stored. The SD card must be clearly identified with the car competition number and handed over to the technical scrutineer in the technical check area when the rules of Parc Fermé apply, as mentioned in 8.1 “SD cards during Parc Fermé”. The organization advises to foresee a spare memory card in case one is confiscated for analysis. The PSCB is owner of the recorded videos and their copyrights. The videos can be used in private circumstances but can’t be distributed to third parties. The camera needs to be positioned in the center of the car. The camera should be mounted in a way that it records the steering wheel and track in front of the car.

Parts should be rigid. A keycord must be attached to the camera and roll cage. This is to avoid a drop of the camera into the pedal box during an incident. Make sure that the keycord doesn’t block the view of the camera

while braking. The use of mounting parts with suction cups is forbidden. The use of cameras on the outside of the cockpit is prohibited.

## **19. Tyres & wheels**

All tyres must be in accordance with the PSCB technical regulations 2026 and sporting regulations 2026. Only Michelin tyres are allowed. During the 2026 season, for qualifying and races, the tyres must be ordered in advance and can only be taken at the event from the official Michelin tyre supplier (Kronos Racing S.A.). For the following sessions, the following tyres are authorized:

### **19.1. Tyre types**

#### **19.1.1. Slick tyres – Qualifying & races**

Registered tyres bought from the official Michelin tyre supplier during an Event of the PSCB 2026.

#### **19.1.2. Wet tyres**

The number of wet tyres is unlimited and will not be registered.

#### **19.1.3. Joker tyres**

Joker tyres will be allowed and are registered tyres bought from the official Michelin tyre supplier during an event of the PSCB 2026.

### **19.2. Sessions / Tyre quota**

- Maximum 8 new slick tyres can be used per car per race event.
- Slick tyres, registered during a previous PSCB race event from the 2026 season.
- Wet tyres.
- Joker tyres, for the entire 2026 season, six additional tyres per competition number can be used as joker tyres to replace damaged tyres. These can be either front or rear axle tyres. In case a competition number misses one or more events, the total amount of joker tyres is reduced by one tyre per missed event. Guest drivers may use one joker tyre per race event. The use of one or more joker tyres is only allowed when a tyre is damaged and must be announced to the technical scrutineers. The technical scrutineer must confirm the damage of the tyre and approve the use of a joker tyre. The marking of a joker tyre by the technical scrutineers is final and cannot be withdrawn afterwards. If a joker tyre is marked in qualification or race it can be used for all races of the race event and on future events for qualifying or race.

### **19.3. Registration**

The registration and delivery of the tyres take place within a certain time frame, announced by the series organizer in the supplementary regulations, the event time schedule, the drivers briefing, or an event bulletin. The series technical manager reserves the right to change the registration time. The entrant has the right to request the tyre registration information stored for his/her cars.

### **19.4. Treatment**

The pattern of the tyres may not be changed. Any chemical, mechanical, or thermal treatment of the tyres is prohibited. Cleaning of the rims is permitted. The usage of a device, heat guns, or any similar devices of any kind to help the removal of rubber abrasion and stones ("tyre scraping") is allowed. The use of heated covers, materials, or other means that change the temperature of the tyres is prohibited for the entire duration of an event. From the time of the pre-start until the end of the session, for the event approved tyres are not allowed to be covered. This applies to slick as well as rain tyres. Tyres can be placed outside to be warmed up by the sunshine. This can only be done in a natural way without manipulations or amplifications of the sun rays.

### **19.5. Tyre damages**

The technical scrutineers, in agreement with the official Michelin tyre supplier, have the right to prohibit the use of a damaged tyre(s), if it seems unsafe to use.

### **19.6. Exceeding the tyre quota**

If any quota is exceeded, a penalty will be determined by the Stewards of the event.

### 19.7. Driver Swap

If a driver changes a team during the season, the driver must use his registered tyres from the previous events during the PSCB 2026 season. A driver cannot change division during the season.

### 19.8. Guest Drivers

Guest drivers must respect the same tyre regulations than full season drivers.

### 19.9. Recap table

Note: The overview found in the table underneath is a brief recapitulation of the detailed tyre regulations found above. In all cases the detailed tyre regulations counts and not this table.

<b>Q &amp; R</b>	- Max. 8 new slick tyres per race event (registered) - Slick tyres from previous event (registered) - Wet tyres
<b>Slick Tyres</b>	Max 8 new tyres per race event
<b>Joker Tyres</b>	6 additional tyres per competition number for the 2026 PSCB season. Guest drivers may use 1 additional tyre per event.
<b>Wet Tyres</b>	Unlimited

### 19.10. Tyre/rim sizes

The use of any other wheels than the originally specified wheels is prohibited.

All wheels must be fitted with TPMS sensors if this is original to the car. The rims are allowed to be painted. It is prohibited to paint or treat any functional surfaces (rim bed, contact area of wheel nuts, mounting surface of the wheel). During all sessions the wheel valve caps must be mounted.

See Table 1 in Part B – Appendices.

## 20. Electronic control units

Throughout the entire event, only the electronic control units coded and sealed by the series organizer for the races are allowed to be used. The electronic control unit incl. the complete wiring harness must be used without modifications. The series organizer or the technical scrutineers reserve(s) the right to check or exchange the electronic control unit or record the engine characteristic data at any time during the event. The series organizer reserves the right to reprogram the electronic control units and to seal the plug-in connectors for reading the electronic control units at any time the start of an event.

It is the competitors responsibility to ensure that the engine electronic control unit is programmed with the latest software as provided on PMRSI.

## 21. Fuel

The only permitted fuel is commercial, unleaded fuel 98 RON Super Plus, or otherwise described in the Supplementary Regulations of a specific event, in compliance with Art. 252.9 of Appendix J (FIA ISC) which must comply with DIN EN 228. All additives are prohibited. All chemical or thermal changes to the fuel are forbidden.

The technical scrutineers shall be entitled to take fuel from a participant's car at any time during the event. At any time of the event until the end of the protest deadline. The entrant must ensure that a minimum amount of 2.0 kg (tolerance of 0.1 kg) can be taken from the corresponding removal point (fuel removal valve) of the car during Parc Fermé. It is the team's (entrant's) responsibility to be able to take a fuel sample of min. 2.0 kg (tolerance of 0.1 kg) at the removal point of the car; if this is not the case, the team (entrant) has the possibility to repair the fuel pump. The fuel indication on the dashboard display can't be used as an argument for not being able to tap off the minimum amount of fuel. The team needs to take a margin into account due to the fuel level gauge not being accurate when the fuel tank is almost empty.

Defueling and refueling of the cars during qualifying and the race is forbidden. At any time, it is forbidden to refuel or defuel in the pit lane. Should there be any circumstances where a team is unable to use a closed-circuit fueling system, then any fuel operations must be performed outside the team's pitbox. In a clear area of at least 3 m in each direction of the car. All personnel working in this area must wear full fireproof clothing (including shoes, gloves, goggles, balaclavas, etc.). The car and all equipment must be grounded to earth properly, and at least two 9kg ABC dry powder or, alternatively, two 5kg CO<sub>2</sub> fire extinguishers with standby

personnel (not involved in any fuel operations) must be present in this area. Under no circumstances must members of the public, entrants, team guests, or unauthorized personnel be permitted in this area where fuel is handled as described above. It is the responsibility of the team (entrant) to ensure that such persons are excluded from the area. Smoking and hot works are prohibited when any operation involving fuel or the fuel cell is in progress

#### **21.1. FIA FT3 Fuel tank**

A FIA FT3 tank is mandatory for all cars. Excluded from this rule are Porsche models that are delivered from the factory without FIA FT3 tank. The standard tank as delivered from the factory is mandatory for this car type.

#### **22. Fire extinguisher**

From the moment that the race car leaves the team's (entrant) tent or garage to attend a qualifying or race session until the end of Parc Fermé, the car's fire extinguisher must be active.

#### **23. General safety**

##### **23.1. Safety stands**

The use of safety stands (securing the car from dropping unintentionally from the air jacks) for any type of work underneath the car is mandatory. Any infringements will be reported to the Stewards of the Event and penalized at the full discretion of the Stewards of the event.

##### **23.2. Compressed air equipment**

For all high-pressure compressors used to fill air bottles, the competitor must be able to show proof that maintenance by a relevant specialist company has been undertaken within the previous 24 months. All compressed air bottles and hoses must not be more than 10 years old at the time of use, and they must show no signs of visible damage. All compressed air bottles must be protected from falling over at any time. Any attached pressure reducers, gauges or valves must be protected from releasing gas or breaking off should they fall over or be knocked or hit in any way.

##### **23.3. Fire prevention**

It is the team (entrant) responsibility to have min two 9kg ABC Dry Powder or alternatively two 5kg CO<sub>2</sub> fire extinguishers present in the teams' tent/awning/garage box at all times. The fire extinguishers must be clearly visible and easily accessible. Any non-compliance will be reported to the Stewards of the event and penalized at the full discretion of the Stewards of the event.

#### **24. Minimum Car weight**

It is the entrants' responsibility to always ensure that during the Event the mandatory minimum weights are reached. The minimum weight must also be observed when the levels of operating liquids are under minimum level. The technical scrutineers shall specify a weight scale to check the weight of the cars. It is referred to here as the "official scale". The installation of ballast is permitted. These must be installed at the position of the passenger's seat. At no time during an event is the weight of a car allowed to be less than the mandatory minimum weight. On the way from the circuit to the Parc Fermé and in the Parc Fermé itself, and on the way to the post-qualifying or race technical scrutineering, under no circumstances is weight allowed to be added to the car. Prior to weighing a car, the technical scrutineers will give the order to a team member to remove the remaining fuel from the fuel tank. After weighing, the value plus 2.0 kg of weighing tolerance shall be added, and this result shall be referenced against the mandatory minimum weight, which must be reached. The mandatory minimum weight of a car is specified further in these regulations. The minimum weight of a car consists of the weight of the car with empty fuel tank.

##### **24.1. Weighing of Cars**

Weighing of Cars is carried out on the official scale. If a Driver is given the signal that his/her car has been selected for weighing, he/she must take the shortest route possible to the weighing area and turn off the engine. If a car cannot reach the weighing area under its own power, it must be brought to the weighing area solely by marshals. If this is not possible, then the technical scrutineers can assign other persons for this purpose.

##### **24.2. Leaving the weighing area**

Without the consent of the technical scrutineers, the car is not allowed to be removed.

### **24.3. Replacement and loss of Car parts**

All car parts that were replaced during the qualifying session and race must be presented to the technical scrutineers without request for inspection. The parts that were removed from the car will be marked by the technical scrutineers if necessary and are not allowed to be modified in any way afterwards. These parts must remain in the pit or in the technical scrutineering tent in sight of the technical scrutineers or their assistants until released by the technical scrutineers. These parts can be considered when determining the weight instead of the replaced parts.

### **24.4. Parc Fermé rules for Car weighing**

Cars that have been specified for weighing are subject to Parc Fermé regulations. It is forbidden to add or remove any substance to/from the car after it has been selected to be weighed. The same applies during the weighing process and after the end of the race. Excluded are actions of the technical scrutineers.

### **24.5. Weighing in below the minimum weight**

If, during the post qualifying or post-race weighing procedure, the car is found to be below the currently applicable minimum weight, the car will immediately be weighed for a second and a third time on the same scales and in the same condition. The maximum value of the 3 weights recorded is regarded as the actual weight of the car. Falling below the minimum weight will be reported to the Stewards of the event.

### **24.6. Bringing the Car to the weighing area**

It is the entrant's responsibility to ensure that the race car entered by him/her can be brought directly to the weighing area when instructed by the Stewards of the event or the technical scrutineers at any time during the event. In any case, Parc Fermé rules apply to the car from the moment of the order until the termination of the weighing process. Moreover, Parc Fermé rules apply to the route to the weighing area and in the weighing area itself. In this area, the only activities on the car are those expressly permitted by the aforementioned persons. If a car is not presented for weighing despite a request, the technical scrutineers will inform the Stewards of the event.

### **24.7. Minimum Car weight per Car type**

See Table 2 in Part B – Appendices

### **24.8. Ballast**

The installation of the ballast box as described in the parts catalogue is mandatory.

The installation of ballast is permitted. Only original ballast components must be used to add weight to the car to reach the minimum car weight. These must be installed in the provided holders at the position of the passenger's seat in accordance with the instructions in the designated technical manual. The ballast weights are identified in the designated spare parts catalogue. The mounting of the ballast base plate (Pn.: 9F1882378) and the ballast cover (Pn.: 9F1801575) are mandatory.

## **25. Ground clearance of Car**

The minimum ground clearance of the car with the driver in the car, tyres at 2.0 bar  $\pm$ 0.1 bar air pressure, must not be less than the specified value, measured at the specified measuring points, at any time during the Event.

### **25.1. Measuring method**

The minimum ground clearance of the car is checked on the measuring surface, using a height gauge, gauge block, or similar. The minimum ground clearance of the car with the driver in the car, tyres at 2.0 bar  $\pm$ 0.1 bar air pressure, must not be less than the specified value, measured at the specified measuring points, at any time during the event. The ground clearance of the car is measured on a surface indicated by the technical scrutineers. This 'surface' can be a measuring plate, a surface exclusively designated for this purpose, or any other surface. The measurement is checked with the car in the state that it ended its last session. This means with the same tyres that the driver ended its last driving session. The remaining fuel, left over from the last driving session, must stay in the car for the ground clearance measurement. The ground clearance measurement is done with the driver on board that ended the last session, together with his full driver's equipment. If the measuring device can be accessed under the measuring points described above, the requirement to comply with the minimum height is satisfied. Any measuring tolerances will be taken into account by the technical scrutineers. The technical scrutineers may at any time in their absolute discretion

check the ground clearance measurement. The technical scrutineers may also use instruments such as measuring calipers or depth gauges to determine the car height. Failure to reach the minimum height will be reported to the Stewards of the event.

During the qualifying sessions, including during the break, in case of a qualifying with a break in the pit lane, it is strictly forbidden to modify the ground clearance, by adjusting the spring rest and/or counter nut of the shock absorbers.

See Table 3 in Part B – Appendices.

The suspension is allowed to be modified within the scope of the specified setting range. All genuine parts must be retained. The max. permissible thicknesses of the spacer washers in the front and rear axle control arms to change the camber angle per car type are shown underneath. Furthermore, it is optional to hide the camber shims with aluminium tape. The trailing arm axle bearing points of the front and rear control arms must be left in the position in which they are delivered.

See Table 4 in Part B – Appendices.

If measured, the camber gauge available at the scrutineering is binding.

A change to the maximum permissible combined thickness of the spacer washers in the front and rear axle control arms can be announced by Stewards of the event by bulletin at any time before or during any Event.

## **26. Seals**

The engine and gearbox do not need to be sealed.

## **27. Penalty for not being compliant with the Technical Regulations**

### **27.1. Penalty 1**

Not being in compliance with the Technical Regulations during the qualifying sessions and/or the post-technical scrutineering of the associated session will be reported to the Stewards of the event and will be penalized with the cancellation of the qualification times achieved by the driver concerned. The driver is allowed, however, to start in the race from the last place on the starting grid. All other drivers, including unqualified drivers, who would be standing on the starting grid behind the penalized driver will move up one place on the starting grid of the associated race. If more than one driver is penalized with the same penalty, their order on the back of the starting grid will be defined by their best qualification times.

### **27.2. Penalty 2**

Not being in compliance with the technical regulations during a race session and/or the post-technical scrutineering of the associated session will be reported to the Stewards of the event and will be penalized with disqualification from the points classification for that race.

### **27.3. Violation resulting in Penalty 1 & 2**

Penalty 1 & 2, as described above, are valid and must be applied in case of any infringement observed regarding the topics listed underneath.

- Minimum car weight
- Minimum ground clearance
- Maximum camber spacer
- Wheelbase dimensions
- Wing dimensions and profile
- Use of unregistered tyres during qualifying or race
- Tyres fitted or any illegal manipulation of them

### **27.4. Other violations**

Other infringements against the technical regulation will result in a penalty decided by the Stewards of the event or otherwise specifically described in these technical regulations. The penalty decided by the Stewards of the event could be penalty 1 & 2.

## Part B: Appendices

**28. Table 1 - Tyre/rim sizes**

Car Type	Slick Front	Slick Rear	Rain Front	Rain Rear	Rim Front	Rim Rear
Porsche 911 GT3 Cup, type 992 + ABS	30/65-18	31/71-18	30/65-18	31/71-18	12Jx18 ET23,5mm	13Jx18 ET44,5mm
Porsche 911 GT3 Cup, type 991 Gen II + ABS	27/65-18	31/71-18	27/65-18	31/71-18	10,5Jx18 ET28mm	12J18 ET53mm
Porsche 911 GT3 Cup, type 991 Gen I + ABS						
Porsche 718 Cayman GT4 RS Clubsport, type 982	25/64-18	27/68-18	25/64-18	27/68-18	9Jx18 ET41mm	10,35Jx18 ET47,5mm
Porsche 718 Cayman GT4 Clubsport MR, type 982 (with air intake)	25/64-18	27/68-18	25/64-18	27/68-18	9Jx18 ET41mm	10,35Jx18 ET47,5mm
Porsche 718 Cayman GT4 Clubsport MR, type 982 (without air intake)						
Porsche 718 Cayman GT4 Clubsport, type 982 (Trophy Spec)						
Porsche Cayman GT4 Clubsport, type 981						

Porsche 911 GT3 Cup (type 992) cars need to use the Michelin N3 (front) and the N3R (rear) type tyres.

Porsche 911 GT3 Cup (type 991) cars need to use the N2 type tyres (front and rear).

718 Cayman GT4 RS Clubsport cars need to use the Michelin N2 & N2R range type tyres.

718 Cayman GT4 Clubsport cars need to use the Michelin N2 (front) and N2R (rear) type tyres.

**29. Table 2 – Minimum Car weight per Car type**

Car Type	Weight
Porsche 911 GT3 Cup, type 992 + ABS	1311kg
Porsche 911 GT3 Cup, type 991 Gen II + ABS	1230kg
Porsche 911 GT3 Cup, type 991 Gen I + ABS	1225kg
Porsche 718 Cayman GT4 RS Clubsport, type 982	1330kg
Porsche 718 Cayman GT4 Clubsport MR, type 982 (with air intake)	1295kg
Porsche 718 Cayman GT4 Clubsport MR, type 982 (without air intake)	1325kg
Porsche 718 Cayman GT4 Clubsport, type 982 (Trophy Spec)	1325kg
Porsche Cayman GT4 Clubsport, type 981	1290kg

**30. Table 3 – Ground Clearance**

Car Type	Front	Rear
Porsche 911 GT3 Cup, type 992 + ABS	72mm	106mm
Porsche 911 GT3 Cup, type 991 Gen II + ABS	78mm	100mm
Porsche 911 GT3 Cup, type 991 Gen I + ABS		
Porsche 718 Cayman GT4 RS Clubsport, type 982	79mm	100mm
Porsche 718 Cayman GT4 Clubsport MR, type 982 (with air intake)	101mm	94mm
Porsche 718 Cayman GT4 Clubsport MR, type 982 (without air intake)	85,0mm	95,0mm
Porsche 718 Cayman GT4 Clubsport, type 982 (Trophy Spec)		
Porsche Cayman GT4 Clubsport, type 981		

**31. Table 4 - max. permissible thicknesses of the spacer washers (“Camber shims”)**

Car Type	Front	Rear
Porsche 911 GT3 Cup, type 992 + ABS	20,0mm	15,0mm
Porsche 911 GT3 Cup, type 991 Gen II + ABS	18,0mm	15,0mm
Porsche 911 GT3 Cup, type 991 Gen I + ABS		
Porsche 718 Cayman GT4 RS Clubsport, type 982	18,0mm	18,0mm
Porsche 718 Cayman GT4 Clubsport MR, type 982 (with air intake)		
Porsche 718 Cayman GT4 Clubsport MR, type 982 (without air intake)		
Porsche 718 Cayman GT4 Clubsport, type 982 (Trophy Spec)		
Porsche Cayman GT4 Clubsport, type 981		

For the competition at Zandvoort, Zolder & Spa Francorchamps the maximum permissible combined thickness of the spacer washers in the front and rear axle control arms off GT3 Cup (type 992) are:

- Front axle: 19.0 mm
- Rear axle: 13.0 mm

and for all GT4 Clubsport cars are:

- Front axle: 18.0 mm

Rear axle: 10.0 mm

## Part C: Specific Technical Descriptions

All cars must meet the technical descriptions of these regulations and Appendix J of the International Sporting Code in full. In addition to the technical regulations according to Part A in these regulations, the following specific technical descriptions are applicable for the respective car types. Technical acceptance of the cars is undertaken by the technical scrutineers.

### Part C1: Specific Technical Regulations according to model year Porsche GT3 Cup, Type 992 (MY'21-'25)

#### 32. General Car description

Porsche 911 GT3 Cup (type 992), MY '21-'25

Concept: Single-seated, near-standard race Car based on the Porsche 911 GT3. For further general descriptions the entrant shall refer to the respective paragraph of these technical regulations.

#### 33. Engine

##### 33.1. General description

- Aluminium six-cylinder rear-mounted boxer engine
- 3,996 cm<sup>3</sup>; stroke 81.5 mm; bore 102 mm
- Max. power: 375 kW (510 hp) at 8400 rpm
- Max. rpm: 8750 rpm
- Single-mass flywheel (Pn: 9F1105272)
- Water cooling with heat management for engine and gearbox
- Four valves per cylinder
- Variable cam phasing (Intake & Exhaust)
- Direct fuel injection
- Required fuel quality: minimum 98 octane, unleaded
- Dry-sump lubrication
- Electronic engine management (Bosch MS 6.6)
- Race exhaust system with regulated race catalytic converter
- Rear silencer with centred exhaust pipes
- Electronic acceleration pedal

##### 33.2. Cooling system:

The classic coolant is prohibited. The cooling system must be filled up with regular water that is mixed with anti-corrosion agent with Porsche spare part number 9F0100628.

For the correct mixture consult the latest version of the technical car manual.

Two coolant supply pipes are allowed to be used as described underneath. The parts listed below must only be installed in the subsequent combination. If one of the components is changed all other accompanying parts must also be changed at the same time.

#### 34. Power transmission (gearbox/differential lock)

##### 34.1. General description

- Porsche six-speed sequential dog-type gearbox
- Gear ratios:
  - Ring & pinion gear 15/23 i = 1.533
  - Final drive 16/39 i = 2.438
  - 1st gear 13/41 i = 3.154
  - 2nd gear 17/40 i = 2.353
  - 3rd gear 20/37 i = 1.850
  - 4th gear 24/36 i = 1.500
  - 5th gear 24/30 i = 1.250
  - 6th gear 28/30 i = 1.071
- Internal pressure-oil lubrication with active oil cooling by oil-water heat exchanger

- Mechanical limited slip differential
- Triple-disc sintered metal race clutch (Assembly: Pn: 9F1141015)
- Paddle shift with electronic shift barrel actuator

### **34.2. Ramp breakover angle**

The ramp breakover angle of the differential lock is 52° (traction) and 35° (overrun). The ramp angles are determined from the axis of rotation (Attachment 2). The number of friction plates and the assembly order shall correspond to the image shown in Attachment 3 and must not be changed. The fitted friction plates must comply in terms of part number, allocation and specification (see parts catalogue of the eligible car).

### **35. Engine oil quick refill**

The use of the optional “oil quick filling kit” as shown in the catalogue is permitted, if the mounting is compliant with the Porsche AG’s official mounting instructions. The hole in the engine lid necessary to fit the quick oil fill must be fully covered by clear Helicopter tape. The use of the engine oil quick fill in pitlane during any PCCB event is prohibited.

### **36. Brakes**

#### **36.1. General description**

Two independent brake circuits with brake pressure sensors for front and rear axle, adjustable by the Driver via brake balance system derivative sensors & Bosch Race ABS (Generation 5).

#### **Front axle:**

- Aluminium 6-piston fixed callipers, one piece.
- Knock back springs behind all 6 pistons.
- Internally vented brake discs, diameter = 380 mm, 32 mm thick,  
Front Left: Assembly: PPN.: 9F1615283A  
Front Right: Assembly: PPN.: 9F1615284A
- Racing brake pads (Pagid). PPN.: 9F1615432.

#### **Rear axle:**

- Aluminium 4-piston fixed callipers, one piece.
- Knock back springs behind all 4 pistons.
- Internally vented brake discs, diameter = 380 mm, 32 mm thick,  
Rear Left: Assembly: PPN.: 9F1615583A  
Rear Right: Assembly: PPN.: 9F1615584A
- Racing brake pads (Pagid), PPN.: 9F1615432B.

Only cars with brake calipers that correspond with the delivery conditions are permitted. It is not permitted to modify the car to endurance brake calipers, even if they might be listed in the parts catalogue

The spoilers on the front wishbones (Pn:9F1407811 and 9F1407812) must be mounted as described in the Technical Manual and are mandatory for each event.

Only standard master brake cylinders are permitted for the 2 brake circuits on the:

- Front axle: (diameter: 19,1 mm, part number: PPN.: 9F1611011B or 9F1611011E)
- Rear axle: (diameter: 17,8 mm, part number: PPN.: 9F1611011D)

Cars delivered with brake master cylinders of 15,9 mm diameter need a replacement of the brake master cylinders with 17,8 mm diameter from the 2026 parts catalogue.

It is permitted to secure the two halves of the airduct element (PPN.: 9F1615457, 9F1615458, 9F1615447 and 9F1.615.448), using a maximum of 3 cable ties around each element, to prevent their separation.

### **37. ABS System**

The use of the original ABS and traction control system is allowed.

All Cars competing in 992 Class are allowed to be equipped with the Bosch Motorsport ABS system (hydraulic power unit Pn: 9F1614095).

The ABS system must not be modified in any way. All genuine parts must be retained and can only be replaced by identical parts. These parts are stated in the Porsche 911 GT3 Cup (Type 992) parts catalogue as released on the Porsche Motorsport Racecar Service Information (PMRSI).

The Competitor must ensure that the working parameters are identical to the ones reported by the supplier in the setup configuration.

Setup can only be modified within the scope of the specified setting range (Dry-Wet switch, 12 positions switch). The Competitor must ensure that the correct ICD and IPS setups are used as mentioned on PMRSI

### **38. Wheel suspension**

#### **38.1. General description front axle**

- Double wishbone suspension, adjustable ride-height, camber and toe.
- Forged control arms and top mounts: Stiffness optimised, spherical bearings with dust protection.
- Wheel hubs with centre lock
- Shock absorbers with motorsport specific valve characteristic, non-adjustable
- Double-blade-type anti-roll bar
- Electric power steering with external control function for easy car manoeuvring
- Tyre pressure monitoring system

#### **38.2. General description rear axle**

- Multilink rear suspension, adjustable in height, wheel camber and track
- Forged control arms and top mounts: Stiffness optimised, spherical bearings with dust protection.
- Wheel hubs with centre lock
- Shock absorbers with motorsport specific valve characteristic, non-adjustable
- Double-blade-type anti-roll bar
- Tyre pressure monitoring system

##### **38.2.1. Camber**

The suspension is permitted to be modified within the scope of the specified setting range. All genuine parts must be retained. The max. permissible thicknesses of the spacer washers in the front and rear axle control arms to change the camber angle are: check in Part B.

Furthermore, it is optional to hide the camber shims with aluminium tape. The trailing arm axle bearing points of the front and rear control arms must be left in the position in which they are delivered. Additionally, the screw positions of the trailing arms at the wishbone bearing points may not be modified. The wheelbase on the left and right sides of the Car must be 2,468 mm +/-15 mm. The measuring points are the centres of the wheel hubs.

##### **38.3. Anti-roll bars**

The anti-roll bars are only permitted to be unhooked provided that one coupling rod of the respective rollbar is completely removed.

Only the setting options for which the technical specifications have been provided are allowed to be used.

Shims are allowed to be used to compensate for the axial clearance of the anti-roll bars on the front and rear axles. This is available in the following version:

1 mm (9F1407728)

Other shims or methods for axial clearance compensation must not be used. The overall axial clearance must not be less than 0,2 mm.

##### **38.4. Shock absorbers/springs**

Only the factory-installed type Multimatic shock absorbers and H&R chassis springs in their original condition are allowed to be used. The following number is stamped on the bump stops of the rear vibration dampers: 9F1412303B. The original delivery condition of the bump stops of the front and rear dampers must not be modified in any way.

### **Vibration damper**

- Front: 9F1413031B

- Rear: 9F1513031B

#### **Bump stop**

- Front: 9F1412303B
- Rear: 9F1412303B

#### **Main spring**

- Front (260 N/mm): 9F1411105B
- Rear (300 N/mm): 9F1511105B

#### **Helper spring**

- Front (2N/mm): 9F1411411B
- Rear (2N/mm): 9F1411411B

### **39. Wheels**

The use of any other wheels than the originally specified wheels is prohibited. All wheels must be fitted with original tyre pressure and temperature sensors. Only the use of the valve caps and valve inserts, provided by the official Michelin Tyre Supplier – Kronos Tyres, are allowed. The rims are allowed to be painted. It is prohibited to paint or treat any functional surfaces (rim bed, contact area, wheel nut, mounting surface of the wheel). Rims may be repaired. The friction strips on the inside of the rim must stay functional and must not be treated in any way.

### **40. Bodywork and dimensions**

#### **40.1. General description**

- Lightweight bodywork with smart aluminium-steel composite construction
- Welded-in roll cage, in compliance with FIA Homologation Regulations for safety cages
- Front bonnet with two air intake ducts for cockpit ventilation and quick release fasteners
- Removable roof section in compliance with the latest FIA safety regulations
- Pre-equipped fixation point for centre safety net
- Pickup points for lifting device
- Modified and widened 911 GT3 fenders, Modified rear wheel arches
- Modified and widened 911 GT3 front-end with spoiler lip
- Modified 911 GT3 rear-end with integrated rain light, in compliance with FIA Homologation Regulations

#### **40.2. Lightweight exterior:**

- Carbon-fibre-reinforced plastic doors with sport-design rear-view mirrors
- Carbon-fibre-reinforced plastic rear engine lid with quick release fasteners
- Carbon-fibre-reinforced plastic adjustable rear wing (11 positions)
- Polycarbonate door windows and rear side windows with ventilation openings
- Polycarbonate windows
- Rear underfloor with NACA ducts for brake and driveshaft cooling

#### **40.3. Modified 911 cockpit:**

- Magnesium sub-frame in light weight design
- Ergonomic driver-oriented centre console
- Switch mask with fluorescent lettering
- Steering wheel with quick release coupling, control panel and shift paddles
- Adjustable steering column with steering angle sensor
- Race bucket seat with longitudinal adjustment in accordance with FIA Standard 8862/2009
- Padding system in 3 sizes (delivery with size M)
- Shock absorbing roll cage safety cover for leg protection at drivers footwell
- Six-point racing safety harness
- 110 litre fuel cell (FT3 safety fuel cell) and „Fuel-Cut-Off“ safety valve in accordance with FIA regulations
- Built-in air jack system (three jacks) with valve mountable on either side of the car

#### **40.4. Water-based paint:**

- Exterior: GT-silver-metallic (M7Z)

- Interior: GT-silver-metallic (M7Z) without clear lacquer finish
- Rims: Platinum semi-matt (0B5)

#### **40.5. Overall Car dimensions and overhangs:**

- The overall length of the Car is 4,585 mm.
- Total width (front axle): 1,920 mm
- Total width (rear axle): 1,902 mm
- Total height: 1,270 mm (wing support highest point)
- Wheelbase: 2,468 mm +/-15 mm
- The front overhang is 1,036 mm +/-15.0mm, measured from the middle of the wheel of the front axle to the leading edge of the Car (first point in the direction of the longitudinal axis, incl. front lip).
- The rear overhang is 1,081 mm +/-15.0mm measured from the middle of the wheel of the rear axle to the rear edge of the Car (last point in the direction of the longitudinal axis, including the exhaust, rear wing excluded).
- The wheelbase on the left and the right sides of the Car is 2,468.0mm +/-15.0mm, measured at the centres of the wheel hubs.

#### **40.6. External bodywork (including windows)**

The delivery status of the bodywork has to be preserved.

##### **40.6.1. Windscreen**

To protect the windscreen and as a safety measure, 'tear-off' screens are allowed to be attached to the windscreen. Fitting will be checked during Technical Scrutineering and must be removed where applicable on request of the technical scrutineers.

##### **40.6.2. Side and rear windows**

Only the genuine Porsche 911 GT3 Cup side and rear windows in their original version is permissible. Additionally, the rear window must remain fixed with the original type of fixing at all times. If a session is declared as a wet session it is permitted to close all slots on the rear side window with transparent tape.

#### **40.7. Cockpit**

##### **40.7.1. Seat**

The adaptation of the seat by removing or adding original Sabelt seat padding shown in green and blue in Attachment 4 is permitted. The use of the different-sized paddings is allowed, also in the areas shown in green color, as long as they are not modified. Upholstery in the bottom part of the seat on top of the paddings shown in green, as long as the original padding is not modified or removed. Upholstery in the form of a foamed seat insert is permitted, as long as the insert is made of fireproof material and colored in black. The use or change is subject to approval by the series organizer. The original seat mounting (seat rails and bracket) must be retained and must not be modified. In addition to the information included in the Technical Manual chapter 5.4.2. Padding System (image 1) the regulations according to FIA Appendix J, Article 253-16 must be respected (image 2). When using padding or a foam insert, this means: Extract FIA Appendix J, Article 253-16 version 11.07.2019. If a foam insert is used between the homologated seat and the driver, minimum lateral support to the driver's head, shoulders, and pelvis must be guaranteed as follows:

-230 mm min. at seat-side-head support along the head-plane.

-180 mm min. at seat-side-shoulder support along the shoulder-plane.

-100 mm min. in height at seat-side-pelvis support along the pelvis-plane over a length of 200 mm min.

This requirement must be verified using a parallelepiped template of dimensions X 200 xY 150 xZ 100 mm.

In this case, the maximum thickness of the padding is no longer limited to 50 mm. However, the surfaces marked green in image 1 must still not be changed/modified.

##### **40.7.2. Ventilation in the passenger compartment**

Only the factory-fitted ventilation pipe (NACA-intake on the front opening hood) is permissible for cockpit ventilation. The ventilation of the windscreen must not be affected. For additional ventilation of the passenger compartment only the existing original ventilation openings in the rear back windows are permissible. The dimension of the NACA-intake port on the Driver's side is allowed to be changed by taping.

##### **40.7.3. Safety Nets**

Every Car must be equipped with the after-sales safety nets as specified in the valid spare parts catalogue and mounted complying with the Porsche AG mounting instructions. These can be found in the Technical Manual, Chapter 5.4

#### **40.8. Roll cage safety padding**

All Porsche GT3 Cup, type 992 Gen I Cars, must be equipped with the mandatory rollcage padding and foot well foam defined in the current Technical Manual and Spare Parts Catalogue of the Car.

#### **40.9. Additional roof hatch accessories**

The car has an opening in the roof in order to make using the KED system easier should it become necessary to rescue the Driver. The roof hatch is located directly above the Driver. The roof hatch is connected to the roof with 7 livelocks which must be accessible at all times (no foiling or painting of live locks is permitted).

#### **41. Aerodynamic devices**

Masking the radiator grilles is prohibited. The original position of the wing section is allowed to be changed within the specified scope for adjustment. Furthermore, entrants are allowed to tape over the full area of the headlight and day/turn signal light lenses with uncoloured transparent Heli tape, without thereby taping over a slot in the bodywork. Apart from the above, taping over of any slots in the bodywork, wings or other permanent parts, joints and openings is not allowed.

It is mandatory to have a strip of tape of maximum 850 mm length, positioned as per the tape in photo below, to cover the slot between the front bumper and bonnet. The strip of tape is optional for the practice and qualifying.



If a session is declared as a wet session it is permitted to close all slots on the rear side window with transparent tape.

The use of the front air scoop (part numbers 9F1.407.811 and 9F1.407.812) is mandatory for each event.

#### **42. Electrical equipment**

From the moment the Cup car enters the track or pitlane to the end of the "Parc Fermé" during qualifying and racing, only the series organizer and personnel nominated by the series organizer are allowed to connect laptops/computers to the Cup cars. The word 'track' is understood as the part of a circuit that is clearly demarcated to race. For the same period, no external connection (also wireless) may be made between the Car and any external equipment other than the car's equipment to read from the antennas of the tyre pressure monitoring system. It is not permitted at any time for any competitor to read any sensors with any equipment, which are not allocated to the competitor's own team. Any breach of this regulation may result in the car being disqualified from qualifying or racing.

##### **42.1. General description**

- 10,3" Porsche colour display
- Porsche logger
- Porsche power box
- Fire extinguishing system (extinguishing agent: Novec gas)
- Lightweight Battery 12 V, 60 Ah (LiFePO4), leak-proof, placed in the co-driver foot well
- Alternator 175 A
- Fan in light weight design
- Single-arm wiper with direct drive (intermittent and continuous operation)

- Digital touchpanel with multi-color back light.
- Three additional center console switches for additional consumers,
- Data connection (Data logger, Video system)

#### **42.2. LED Lighting system:**

- Main headlight
- LED daytime running light
- LED rear lighting system and rain light in compliance with the latest FIA Homologation Regulation

#### **42.3. Optionally, the usage of the following electrical equipment is permitted:**

AS Sensor GPS (9F2927748)

#### **43. Fuel circuit**

Only the original fuel system is permitted in combination with the after-sale defueling kit. It is described in the current Technical Manual as “option defueling-kit standard tank”. All Cars must be equipped with this defueling kit. All parts shown in the spare parts catalogue indicated for long distance races are prohibited.

The running of the Car using the service position of the fuel pumps is prohibited, as long as there is no technical issue with the system. The system may not be used with any of the pumps switched to service position for more than one lap.

#### **44. Lubrication system**

##### **44.1. Lubricants**

##### **44.1.1. Engine:**

Mobil 1 ESP X4 0W40 or Mobil 1 C40 GT 0W40 engine oil is mandatory. All additives are prohibited.

##### **44.1.2. Transmission:**

Mobilube 1 SHC 75W-90 transmission oil is mandatory. All additives are prohibited. No less than the minimum quantity of transmission oil as specified in the Technical Manual must be used at all times during the Event.

## Attachment 1: Ballast weights

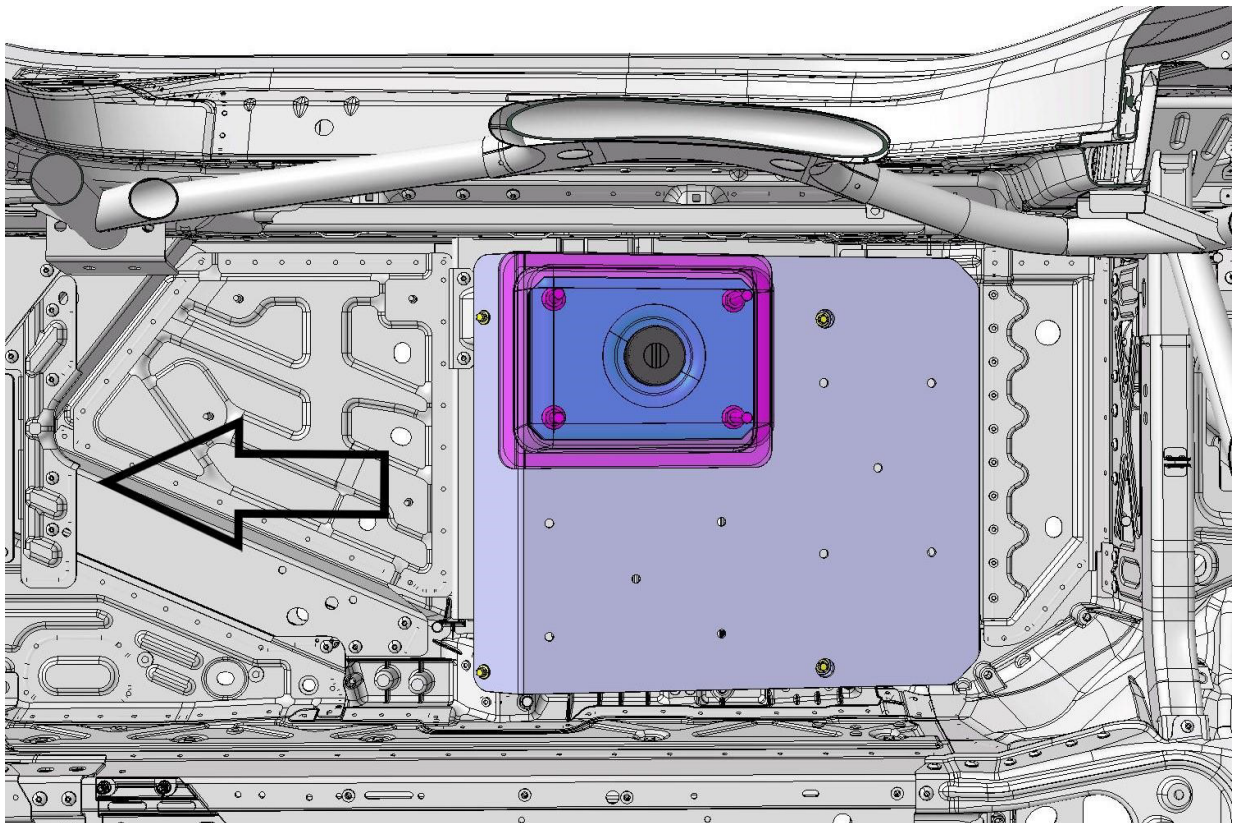

Auxiliary weights part numbers:

Part	number	alternative number (previous model)
AUXILIARY WEIGHT 2KG/6MM	9F1801141	99150484800
AUXILIARY WEIGHT 3,4KG/10MM	9F1801141A	99150484801
AUXILIARY WEIGHT BIG 6,8KG/20MM	9F1801141B	99150484802
COVERING AUXILIARY WEIGHT	9F1801575	9915048659B
KNURLED NUT COVERING	WHS001903	9915048529B

### Attachment 2: Differential lock ramp breakover angle

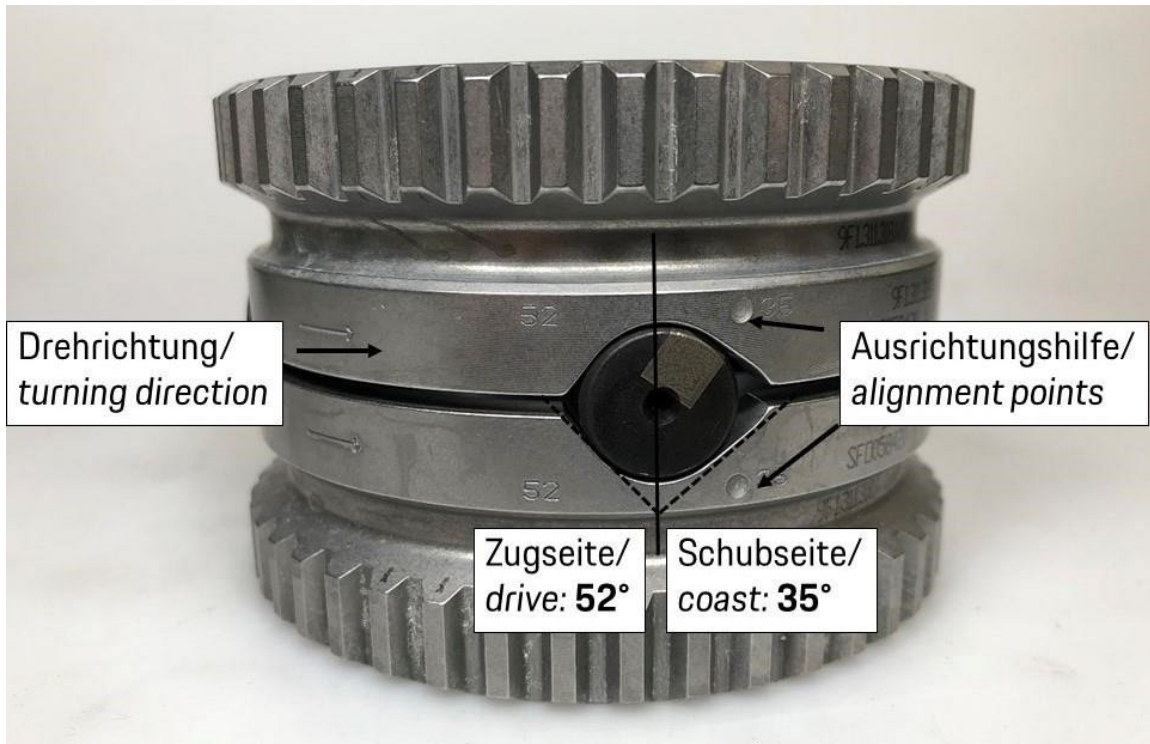

### Attachment 3: Differential design

The differential is fitted with 12 friction surfaces (12FF) as standard. The arrangement of the parts is shown in detail in the image:

PP = Pressure Plates  
CD = Clutch Discs  
FF = Friction Plates

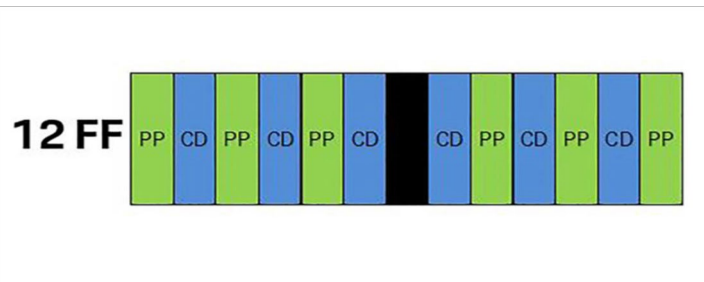

**Attachment 4: Seat**

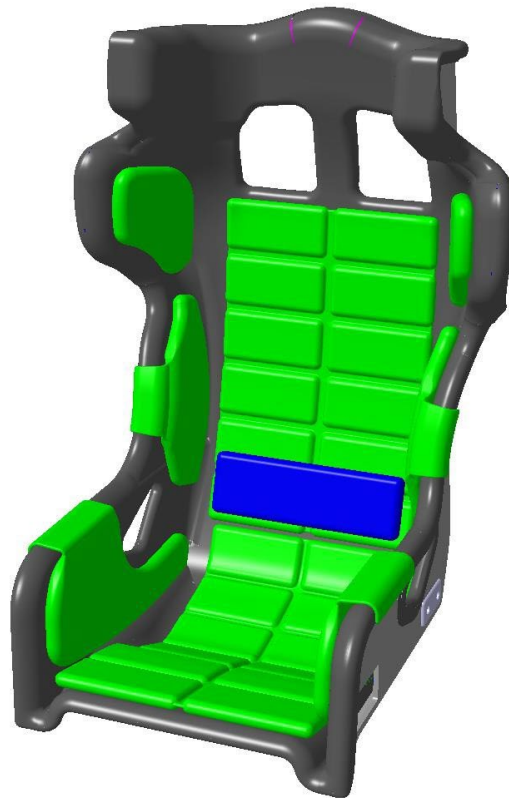

**Attachment 5: Timing transponder (Mandatory for all competing Cars)**

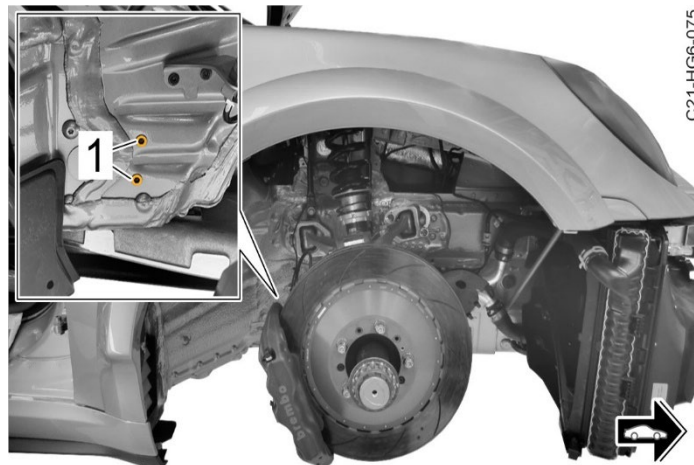

**Attachment 6: Ride height measuring positions**

**Positionen Fahrhöhenmesspunkte/ ride height measuring positions**

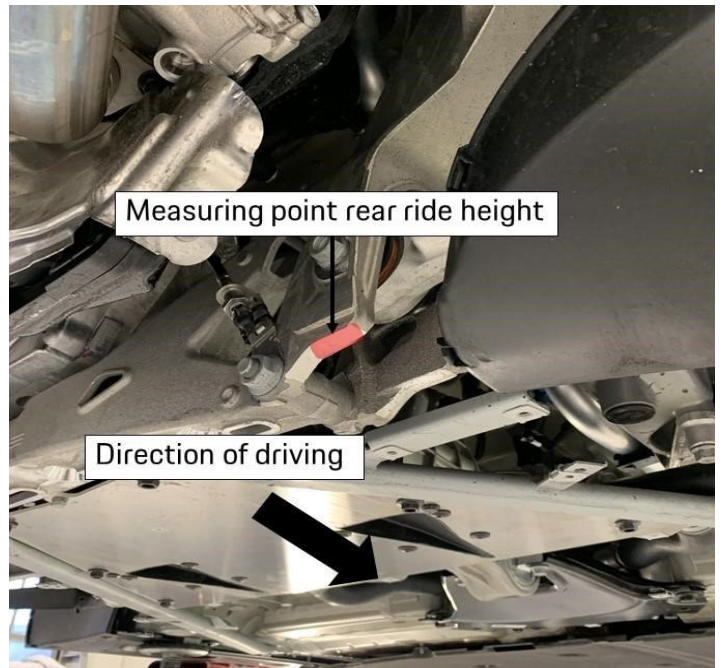
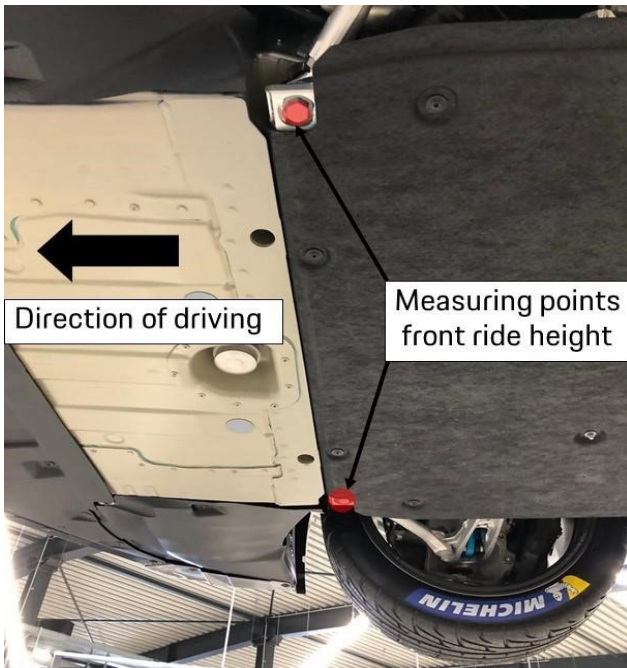
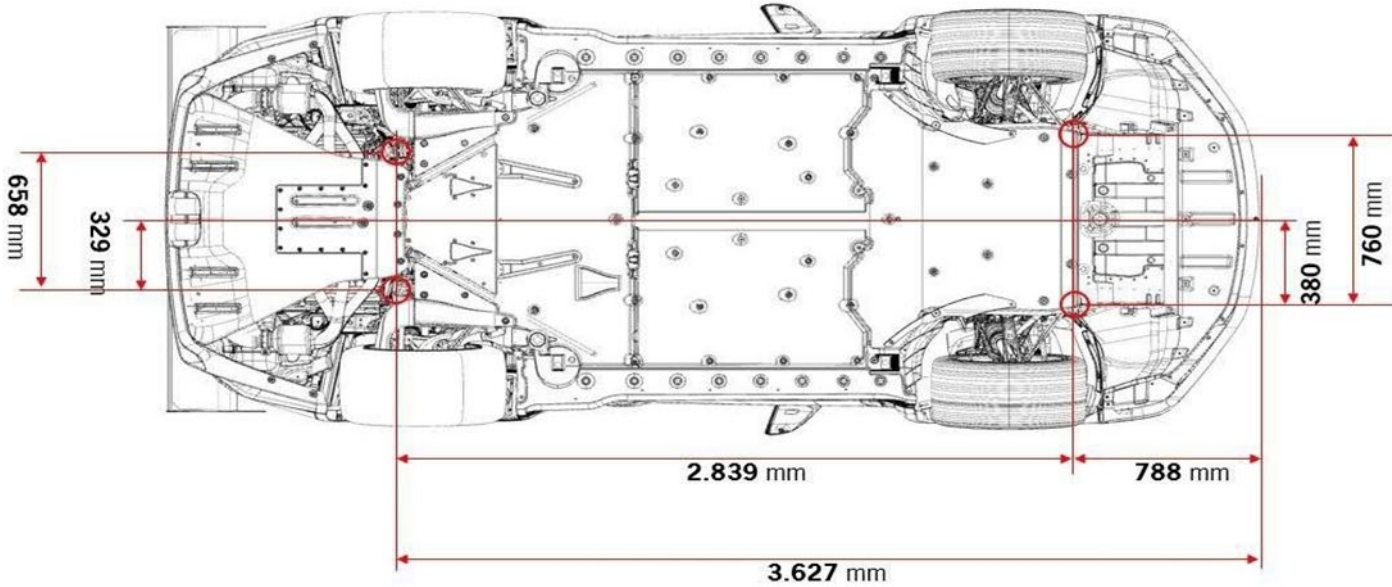

## Part C2: Specific Technical Regulations according to model year Porsche 911 GT3 Cup, Type 991, Gen II ('17 – '19)

### 45. General information

Technically identical Cars with the designation Porsche 911 GT3 Cup (type 991 Gen II), built by Porsche AG in a small production run on the basis of the Porsche 911 GT3, shall be used for the Series. Cars of model year 2017 – 2019 (see following general Car description) are permitted. The Cars must comply with the requirements of these Technical Regulations. Technical acceptance of the Cars is undertaken by the Technical Scrutineers. In addition to the General PEB Technical Regulations, the following specific Technical Regulations are applicable.

### 46. General Car description

Porsche 911 GT3 Cup (type 991 II), MY 2017 - 2019

Concept: Single-seated, near-standard race Car based on the Porsche 911 GT3. For further general descriptions the entrant shall refer to the respective paragraph of this technical regulations.

### 47. Engine

- Aluminium six-cylinder rear-mounted boxer engine
- 3,996 cm<sup>3</sup>; stroke 81.5 mm; bore 102 mm
- Max. power: 357 kW (485 hp) at 7250 – 8000 rpm
- Max. rpm: 8,500 rpm
- Single-mass flywheel (9A110203991)
- Water cooling with heat management for engine and gearbox
- Four valves per cylinder
- Variable cam phasing (Intake & Exhaust)
- Direct fuel injection
- Required fuel quality: minimum 98 octane, unleaded
- Dry-sump lubrication
- Electronic engine management (Bosch MS 4.6 NG)
- Race exhaust system with regulated race catalytic converter
- Rear silencer with centred exhaust pipes
- Electronic acceleration pedal

### 48. Power transmission (gearbox/differential lock)

General description: Porsche six-speed sequential dog-type gearbox

Gear ratios:

- Ring & pinion gear 14/22	i = 1.571
- Final drive 17/41	i = 2.412
- 1st gear 13/41	i = 3.154
- 2nd gear 17/40	i = 2.353
- 3rd gear 19/36	i = 1.895
- 4th gear 19/29	i = 1.526
- 5th gear 24/30	i = 1.250
- 6th gear 34/35	i = 1.029

- Internal pressure-oil lubrication with active oil cooling by oil-water heat exchanger
- Mechanical limited slip differential
- Triple-disc sintered metal race clutch (9911160019A)
- Pneumatic gear shift activation (paddle shift)

#### 48.1. Ramp breakover angle

The ramp breakover angle of the differential lock is 52° (traction) and 30° (overrun). The ramp angles are determined from the axis of rotation, see underneath. The number of friction plates and the assembly order shall correspond to the image shown underneath, and must not be changed. The fitted friction plates must comply in terms of part number, allocation and specification (see parts catalog of the eligible Car).

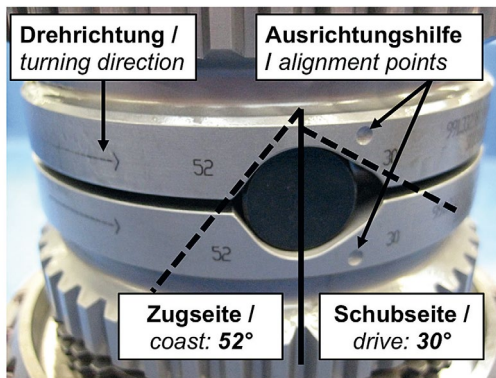

Tellerfeder / belleville spring
Druckring / disk ring
Außenlamelle / pressure plate
Innenlamelle / clutch disk
Außenlamelle / pressure plate
Innenlamelle / clutch disk
Außenlamelle / pressure plate
Innenlamelle / clutch disk
Druckstück / thrust piece
Druckstück / thrust piece
Innenlamelle / clutch disk
Außenlamelle / pressure plate
Innenlamelle / clutch disk
Außenlamelle / pressure plate
Innenlamelle / clutch disk
Außenlamelle / pressure plate
Druckring / disk ring
Tellerfeder / belleville spring

#### 48.2. Transmission emergency function

After the transmission emergency function has been switched on by the Driver, the Car must immediately return to the pit lane. The Car is not allowed to leave the pit lane again until this function has been deactivated.

#### 49. Brakes

Two independent brake circuits with brake pressure sensors for front and rear axle, adjustable by the Driver via brake balance system.

##### Front axle:

- Aluminium 6-piston fixed calipers, one piece
- Internally vented brake discs, diameter = 380 mm, 32 mm thick,
  - Front Left: Assembly: 991.351.105.8A, Disc: 38032005445
  - Front Right: Assembly: 991.351.106.8A, Disc: 38032005446
  - Brake pads: free to chose

##### Rear axle:

- Aluminium 4-piston fixed calipers, one piece
- Internally vented brake discs, diameter = 380 mm, 30 mm thick,
  - Rear Left: Assembly: 991.352.107.8A, Disc: 38030004745
  - Rear Right: Assembly: 991.352.108.8A, Disc: 38030004746
  - Brake pads: free to chose

All Cars' cooling air hoses must be mounted with 2 hose clips (PPN.: 99951273701), one at each end of each air hose. This to prevent that the hose slips off from its supports.

Only standard master brake cylinders are permitted for the 2 brake circuits on the

- Front axle: (diameter: 17.8 mm, PPN.: 991.355.170.8C, 991.355.170.8E)
- Rear axle: (diameter: 17.8 mm, PPN.: 991.355.170.8C, 991.355.170.8E)

A knock-back spring must be installed in each case under each brake piston of all brake calipers. External thermal or chemical treatment of these springs is prohibited. Only the following parts are allowed to be used: Front axle: 991.351.963.8A & Rear axle: 991.352.963.8A

The use of ABS system or traction control is allowed. Both Bosch M4 or M5 systems are permitted. In case an ABS system is mounted, the use of the master brake cylinder with Porsche part nr 991.355.170.8E is mandatory.

It is allowed to equip the brake caliper lines with quick connectors.

The ABS system must not be modified in any way. All genuine parts must be retained and can only be replaced with identical Manthey Racing parts. The Competitor must ensure that the working parameters are identical to the ones reported by the supplier in the setup configuration. Setup can be only modified within the scope of the specified setting range (dry-wet switch, 12 positions switch). The Competitor must ensure that the correct ICD & IPS setups are used. The Ecu must be set to ABS mode = ON by using the Bosch RaceCon Software.

#### 50. Steering (steering wheel/hub extension)

The position of the steering wheel on the front axle control arm is determined by spacer washers with a thickness of 8.5 mm (left: 991.341.613.8A, right: 991.341.613.7B). Hub extensions may be used. Furthermore, the parts used must be original Porsche parts. The standard longitudinal and height adjustment facility is allowed to be used. Line 991.347.775.8A of the steering gear must be equipped with a vibration damper 8K0.611.797.E or alternatively 8K0.611.797.F, see delivery condition.

## 51. Wheel suspension

### 51.1. General description front axle

- McPherson suspension strut, adjustable in height, wheel camber and track
- Forged struts
- Optimized stiffness
- Double shear track rod connection
- Heavy-duty spherical bearings
- Wheel hubs with center lock
- Racing shock absorbers, non-adjustable
- Forged & adjustable top mounts
- Double-blade-type anti-roll bar
- Electrohydraulic power steering with external control function for easy Car manoeuvring
- Tyre pressure monitoring system

### 51.2. General description rear axle

- Multilink rear suspension, adjustable in height, wheel camber and track
- Forged struts
- Optimized stiffness
- Double shear track rod connection
- Heavy-duty spherical bearings
- Wheel hubs with center lock
- Racing shock absorbers, non-adjustable
- Forged top mounts
- Double-blade-type anti-roll bar
- Tyre pressure monitoring system

### 51.3. Trailing arm

The screw positions of the trailing arms at the wishbone bearing points may not be modified (see pic underneath). The wheelbase on the left and right sides of the Car must be 2,456 mm +/-15 mm. The measuring points are the centres of the wheel hubs.

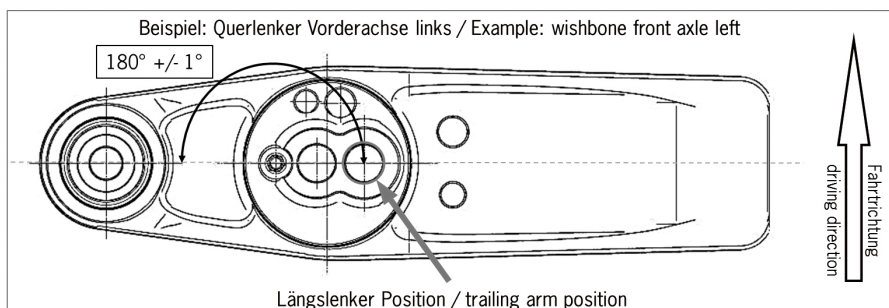

### 51.4. Anti-roll bars

The anti-roll bars are only allowed to be unhooked provided that no parts are removed in the process. Only the setting options for which the technical specifications have been provided are allowed to be used. Shims are allowed to be used to compensate for the axial clearance of the anti-roll bars on the front and rear axles. These are available in the following versions: 1 mm (991.343.761.8A) 2 mm (991.343.761.8B) Other shims or methods for axial clearance compensation must not be used. However, the overall axial clearance must not be less than 2 mm referred to each anti-roll bar.

### 51.5. Shock absorbers/springs

Only the factory-installed type Sachs shock absorbers and H&R chassis springs in their original condition are allowed to be used. The following number is stamped on the bump stops of the rear vibration dampers: 0049 5111 0 250. The original delivery condition of the bump stops of the front and rear dampers must not be modified in any way.

Damper:	Front: 991.343.045.8D	Rear: 991.333.051.8A
Bump stop:	Front: 991.343.677.8A	Rear: 991.333.677.8A
Main spring:	Front (240 N/mm): 991.343.531.8C	Rear (260 N/mm): 991.333.531.8C

Helper spring:

Front (75/60/45): 996.343.537.90

Rear (80/60/60): 997.333.537.90

## 52. **Bodywork**

### 52.1. General description

- Lightweight bodywork with smart aluminium-steel composite construction
- Welded-in roll cage, in compliance with FIA Homologation Regulations for safety cages
- Front bonnet with two air intake ducts for cockpit ventilation and quick release fasteners
- Removable roof section in compliance with the latest FIA safety regulations
- Pre-equipped fixation point for center safety net
- Pickup point for lifting device
- Modified and widened 911 GT3 fenders
- Modified rear wheel arches
- Modified and widened 911 GT3 front-end with spoiler lip
- Modified 911 GT3 rear-end with integrated rain light, in compliance with FIA Homologation Regulation

### 52.2. Lightweight exterior

- Carbon-fibre-reinforced plastic doors with sport-design rear-view mirrors
- Carbon-fibre-reinforced plastic rear engine lid with quick release fasteners
- Carbon-fibre-reinforced plastic adjustable rear wing (9 positions)
- Polycarbonate door windows and rear side windows with ventilation openings
- Polycarbonate rear window
- Rear underfloor with NACA ducts for brake and driveshaft cooling

Door retaining bolts which are mounted in the door hinges can be changed by a non-Porsche genuine bolts. This should be a threaded bush bolt with a female 4mm Allen head M8x1x16. You can purchase this item from the Porsche Sprint Challenge Benelux Support team (pic underneath).



### 52.3. Modified 911 cockpit:

- Magnesium sub-frame in light weight design
- Ergonomic Driver-oriented center console
- Switch mask with fluorescent lettering
- Steering wheel with quick release coupling, control panel and shift paddles
- Adjustable steering column with steering angle sensor
- Race bucket seat with longitudinal adjustment, Homologated to latest FIA requirements
- Individual padding system (delivery with size M)
- Shock absorbing roll cage safety cover for leg protection at Drivers footwell
- Six-point racing safety harness
- 100 litre fuel cell (FT3 safety fuel cell) and „Fuel-Cut-Off“ safety valve in accordance with FIA regulation
- Built-in air jack system (three jacks) with valve mountable on both sides of the Car

### 52.4. Water-based paint:

- Exterior: white C9A
- Interior: white filler-coat, no clear-coat finish

## 53. **Overall Car dimensions and overhangs**

- The overall length of the Car is 4,577 mm.
- Total width: 1,978 mm
- Total height: 1,248 mm
- Wheelbase: 2,456 mm +/-15 mm

- The front overhang is 1,046 mm, measured from the middle of the wheel of the front axle to the leading edge of the Car (first point in the direction of the longitudinal axis, incl. front lip).
- The rear overhang is 1,075 mm measured from the middle of the wheel of the rear axle to the rear edge of the Car (last point in the direction of the longitudinal axis, including the exhaust, rear wing excluded).

#### 54. **External bodywork**

The delivery status of the bodywork has to be preserved.

##### 54.1. **Windscreen**

In addition to the original part, windscreens of the 911 GT3 Cup MY 2013-2017 with the part number 991.541.911.00 are allowed to be used, as well as windscreens of the Porsche 911 GT3 street Car with part number 9P1845011C. Heated windscreens with part number 991.541.111.8B are permitted. The windscreen is allowed to be connected to the electrical system of the Car and the heating function is allowed to be used. To protect the windscreen and as a safety measure, 'tear-off' screens are allowed to be attached to the windscreen. Fitting will be checked during Technical Scrutineering and must be removed where applicable on request of the Technical Scrutineers.

##### 54.2. **Side and rear windows**

Only the genuine Porsche 911 GT3 Cup side and rear windows in their original version are permissible. Additionally, the rear window must remain fixed with the original type of fixing at all times.

If a session is declared as a wet session it is permitted to close all slots on the rear side window with transparent tape.

#### 55. **Cockpit**

##### 55.1. **Safety Nets:**

It is mandatory to use the after sales safety nets as specified in the valid spare parts catalog and mounted complying with the Porsche AG mounting instructions (see pic underneath)

##### 55.2. **Seat:**

The adaption of the seat by removing or adding of original Recaro seat padding is forbidden in the areas of the seat shown in green colour on the illustration underneath. Any modification of the seat padding shown in green colour is strictly prohibited. The use of the different sizes paddings is allowed, also in the areas shown in green colour, as long as they are not modified. An upholstery in the bottom part of the seat on top of the paddings shown in green, as long as the original padding is not modified or removed. An upholstery of the areas shown in yellow colour is allowed by either using original Recaro paddings or using a foamed seat insert, as long as the insert is made of fireproof material, coloured in black and its maximum thickness at any point does not exceed 50 mm in size. The use or change is subject to approval by the Series Organizer. The preferred supplier for padding components is the seat manufacturer (Recaro). The original seat mounting (seat rails and bracket) must be retained and must not be modified.

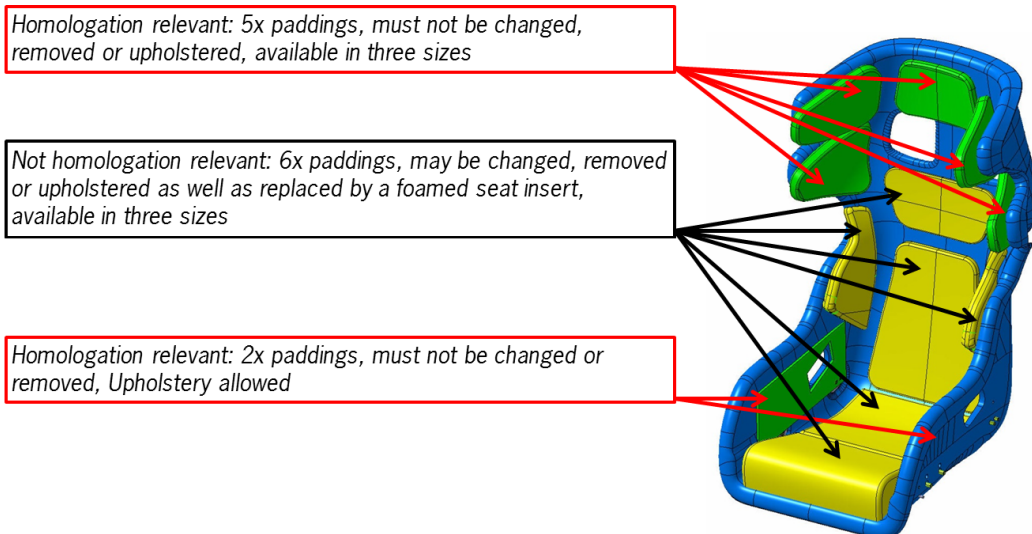

##### 55.3. **Roll cage safety padding**

All Porsche GT3 Cup, type 991 Gen II Cars, must be equipped with the mandatory rollcage padding

All Porsche GT3 Cup, type 991 Cars, must be equipped with the mandatory rollcage padding located in the Drivers footwell (PPN: 9F0.880.413)

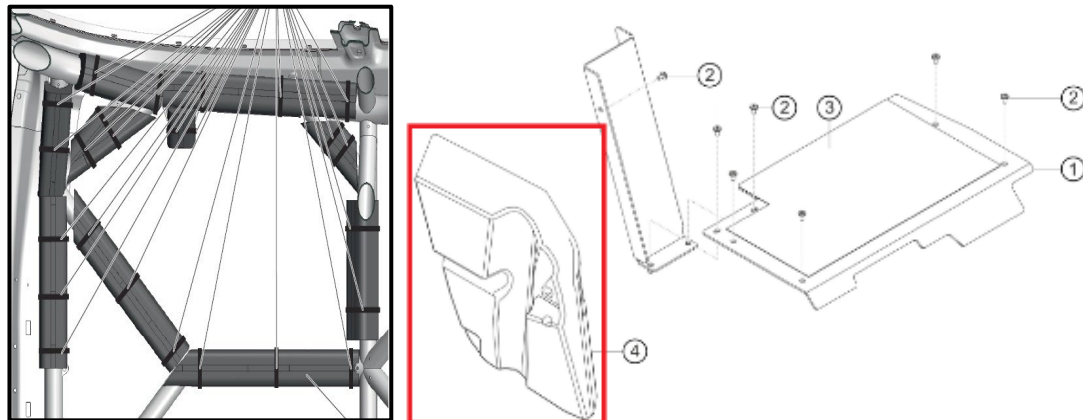

#### 55.4. Additional roof hatch accessories

The Car has an opening in the roof in order to make using the KED system easier should it become necessary to rescue the Driver. The roof hatch is located directly above the Driver and with the dimension of the opening 565 x 475 mm. The roof hatch is connected to the roof via 7 livelocks which must be accessible at all times (no foiling or painting of live locks).

#### 56. Aerodynamic devices

The original position of the wing section is allowed to be changed within the specified scope for adjustment. One strip of transparent adhesive tape (max. 80 mm long, 20 mm wide) is permitted as a fixing element on the headlights, the tail lights, the front wheel covers at a 90° angle in relation to the particular gaps that are taped over. Furthermore, entrants are allowed to tape over the full area of the headlight lenses with transparent Heli tape, without thereby taping over a slot in the bodywork. Apart from the above, taping over of any slots in the bodywork, wings or other permanent parts, joints and openings is not allowed. It is strictly prohibited to cover the radiator grills

#### 57. Electrical equipment

##### 57.1. General description

- COSWORTH colour display ICD with integrated fault diagnosis & electrical system control unit IPS32
- Electronic throttle system
- Fire extinguishing system (extinguishing agent: gas)
- Battery 12 V, 70 Ah (AGM), leak-proof, placed in the co-Driver foot well
- Alternator 175 A
- Fan in light weight design
- Wiper with direct drive (intermittent and high speed function)

##### 57.2. Lighting system

- Bi-xenon-headlight & LED daytime running light
- LED rear lighting system and rain light in compliance with the latest FIA Homologation Regulation
- Two additional switches in the centre console for additional power consumers
- CAN connection (data logger, video system)

#### 58. Fuel circuit

Only the fuel system permitted for the Porsche 911 GT3 Cup Cars of model years 2017-2019 are allowed to be installed. Additionally, to the original fuel system, every Car can be equipped with the after-sales defueling kit

- breakaway coupling: 2x 9971101918C
- sealing washer: 2x 9912018839A
- support washer: 2x WHT004800
- adapter piece: 1x 9F0201156
- drain hose: 1x 9F0201627
- clamp: 1x 90017101401

The running of the Car using the service position of the fuel pumps is prohibited, as long as there is no technical issue with the system. The system may not be used with any of the pumps switched to service position for more than one lap.

#### **59. Optional parts**

All parts found in the parts catalogue, from the eligible Car, as indicated as an option are allowed to be used. Including endurance parts that aren't permitted in a regular Porsche One-Make-Serie.

#### **60. Lubrication system**

Engine: Mobil 1 0W-40 engine oil is recommended. All additives are prohibited.

Transmission: Mobilube 1 SHC 75W-90 transmission oil is recommended.

All additives are prohibited. There has to be a minimum of 2.7 litres of transmission oil in the gearbox at all times during the Event.

#### **61. Fender guide plates**

All Cars must be equipped with air guide plates for the front fenders left and right hand side. (PPN: 9F0.807.683, 9F0.807.684)



#### **62. Additional radiator protection**

For all Porsche GT3 Cup Cars, Type 991 (MY2013 – 2019), it is mandatory to cover the small cooling ducts of the side radiators with the radiator mesh. (PPN.: 99150571381, 99150571481)

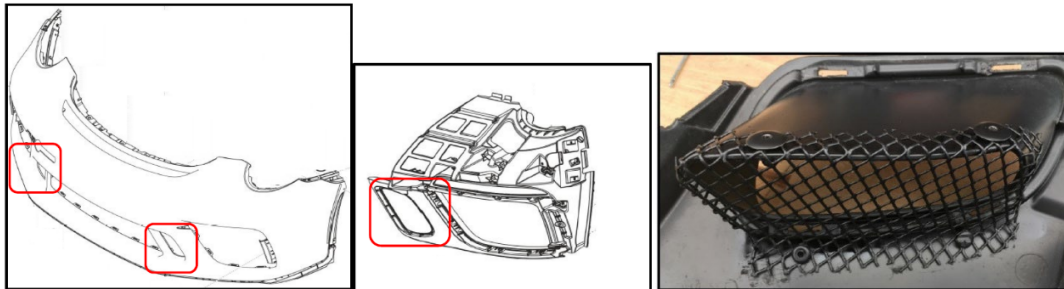

#### **63. Safety Nets**

Every Car must be equipped with the after-sales safety nets as specified in the valid spare parts catalog and mounted complying with the Porsche AG mounting instructions.

Gen 1: Only the left net, Gen 2: left and centre net.

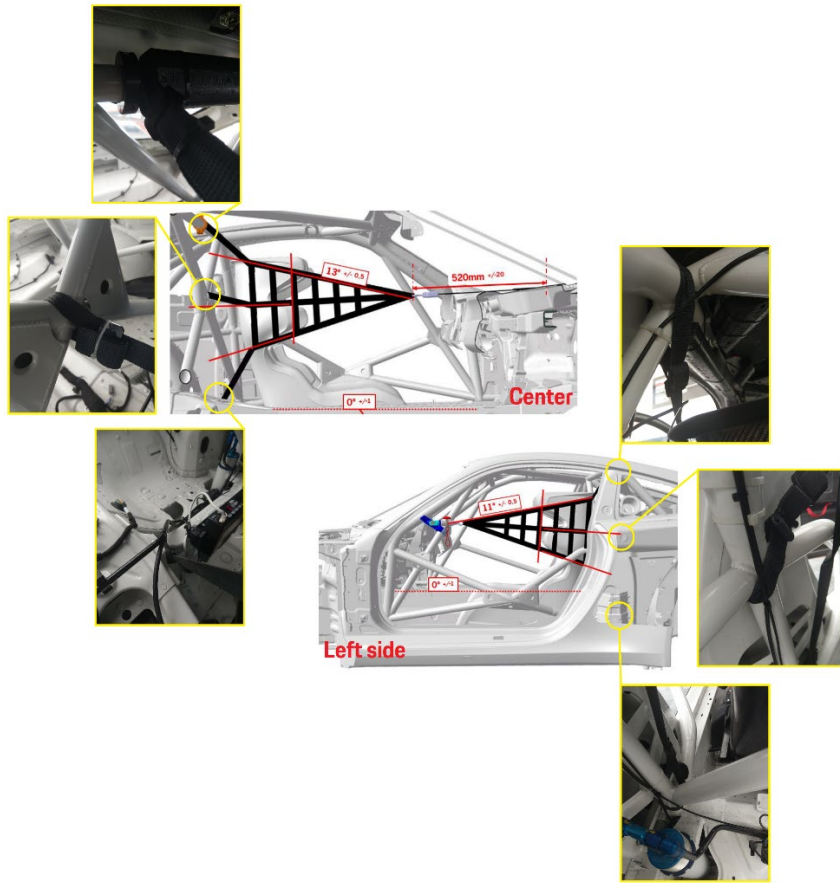

## Part C3: Specific Technical Regulations according to model year Porsche 911 GT3 Cup, Type 991, Gen I ('13 – '16)

### 64. General information

Technically identical Cars with the designation Porsche 911 GT3 Cup (Type 991), built by Porsche AG in a small production run on the basis of the Porsche 911 GT3. Only Cars of model year 2016, 2015 as well as of model year 2013 and 2014 with the required modifications according to the manual. The Cars must comply with the requirements of these 2016 Technical Rules. Technical inspection of the Cars is under taken by the Technical Scrutineers. Everything that is not expressly permitted in this regulation is prohibited. Allowed changes must not result in any infringements of the rules or any changes that are not permitted.

### 65. General Car description

Porsche 911 GT3 Cup (type 991), MY 2013 - 2016

Concept: Single-seated, near-standard race Car based on the Porsche 911 GT3. For further general descriptions the entrant shall refer to the respective paragraph of this technical regulations.

### 66. Engine

- Aluminium rear-mounted flat-six engine
- 3,800 cm<sup>3</sup>; stroke 76.4 mm; bore 102.7 mm
- Max. power: 338 kW (460 hp) at 7,500 rpm
- Max. engine speed: 8,500 rpm
- Single-mass flywheel (99710204192)
- Water cooling with thermal management for engine and gearbox
- 4-valve technology
- Sequential multi-point fuel injection
- Fuel octane rating: minimum 98 octane premium unleaded
- Dry-sump lubrication
- Electronic engine management (Bosch MS 4.6)
- Race exhaust system with regulated catalytic converter
- Rear silencer with twin tailpipe in central arrangement
- Electronic accelerator pedal

The original screws for fixation of the exhaust system are allowed to be replaced by stud bolts and hexagon nuts. Only the following parts are allowed to be used: 4 x studs M10x70 8.8: 999.062.170.02 & 4 x nuts M10: 900.377.011.01

### 67. Power transmission (gearbox/differential lock)

General description: Porsche 6-speed sequential constant-mesh transmission

- |                      |       |           |
|----------------------|-------|-----------|
| - Ring & pinion gear | 14/22 | i = 1.571 |
| - Final drive        | 17/41 | i = 2.412 |
| - 1st gear           | 13/41 | i = 3.154 |
| - 2nd gear           | 17/40 | i = 2.353 |
| - 3rd gear           | 19/36 | i = 1.895 |
| - 4th gear           | 19/29 | i = 1.526 |
| - 5th gear           | 24/30 | i = 1.250 |
| - 6th gear           | 34/35 | i = 1.029 |
- Internal pressure-oil lubrication with active oil cooling
  - Mechanical limited slip differential
  - Triple-disc sintered metal race clutch (9911160019A)
  - Pneumatic paddle shift system (Megaline)

#### 67.1. Ramp breakover angle

The ramp breakover angle of the differential lock is 52° (traction) and 30° (overrun). The ramp angles are determined from the axis of rotation, see underneath. The number of friction plates and the assembly order

shall correspond to the image shown underneath and must not be changed. The fitted friction plates must comply in terms of part number, allocation and specification (see parts catalog of the eligible Car).

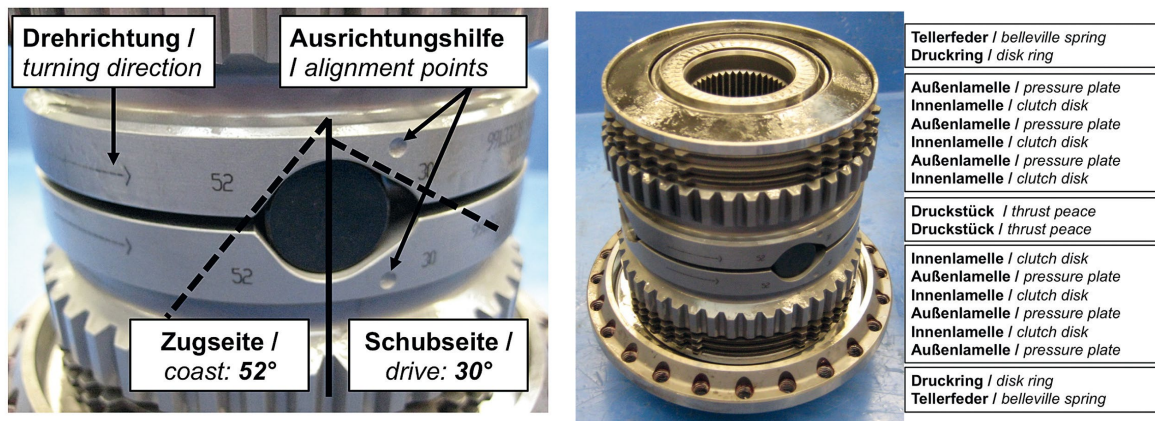

### 67.2. Transmission emergency function

After the transmission emergency function has been switched on by the Driver, the Car must immediately return to the pit lane. The Car is not allowed to leave the pit lane again until this function has been deactivated.

### 68. Brakes

Two independent brake circuits with brake pressure sensors for front and rear axle, adjustable by the Driver via brake balance system.

#### Front axle:

- Aluminium 6-piston fixed calipers, one piece
- Internally vented brake discs, diameter = 380 mm, 32 mm thick,
  - Front Left: Assembly: 991.351.105.8A, Disc: 38032005445
  - Front Right: Assembly: 991.351.106.8A, Disc: 38032005446
- 'Sprint' racing brake pads: 991.351.942.8A  
'Endurance' racing brake pads: 991.351.942.8B
- Optimized ventilation routing (PPN: 9913414848A, 9913414838A)

#### Rear axle:

- Aluminium 4-piston fixed calipers, one piece
- Internally vented brake discs, diameter = 380 mm, 30 mm thick,
  - Rear Left: Assembly: 991.352.107.8A, Disc: 38030004745
  - Rear Right: Assembly: 991.352.108.8A, Disc: 38030004746
- 'Sprint' racing brake pads: 991.352.942.8A  
'Endurance' racing brake pads: 991.352.942.8B
- Optimized ventilation routing: Cooling air hose (PPN: 9915055738A) + mandatory driveshaft cooling (PPN.: 9915753348A, 9915753338A)

All Cars' must be equipped with the mandatory additional brake and driveshaft -air scoops (PPN: 9915753348A, 9915753338A). Also the cooling hose must be update to the Gen II version (PPN: 9915055738B). The air hoses must be mounted with 2 hose clips (PPN: 99951273701), one at each end of each air hose. This to prevent that the hose slips of from its supports.

A knock-back spring must be installed in each case under each brake piston of all brake calipers. External thermal or chemical treatment of these springs is prohibited. Only the following parts are allowed to be used: Front axle: 991.351.963.8A & Rear axle: 991.352.963.8A

The use of ABS system or traction control is allowed. In case an ABS system is mounted, the use of the master brake cylinder with Porsche part nr 991.355.170.8E is mandatory. It is allowed to equip the brake caliper lines with quick connectors.

All 991 GT3 Cup model year 2016 Cars MUST be modified before further use. The master cylinder pushrod must be changed by the pushrod with part number 9914239498A.

## 69. Steering (steering wheel/hub extension)

The position of the steering wheel on the front axle control arm is determined by spacer washers with a thickness of 8.5 mm (9913416138A). No hub extensions are allowed to be installed. The standard longitudinal and height

adjustment facility is allowed to be used. Line 991.347.775.8A of the steering gear must be provided with a vibration damper 8K0.611.797.E in the arrangement as shown.

## 70. Wheel suspension

### 70.1. General description front axle

- McPherson suspension strut, adjustable in height, wheel camber and track
- Forged struts
- Optimised stiffness
- Two-shear connection
- Heavy-duty spherical bearings
- Wheel hubs with central locking
- Racing shock absorbers, non-adjustable
- Forged supporting mounts
- Double-blade-type anti-roll bar
- Power steering with electrohydraulic pressure feed

### 70.2. General description rear axle

- Multi-link rear axle, adjustable in height, wheel camber and track
- Forged struts
- Optimised stiffness
- Two-shear connection
- Heavy-duty spherical bearings
- Wheel hubs with central locking
- Racing shock absorbers, non-adjustable
- Forged supporting mounts
- Double-blade-type anti-roll bar

### 70.3. Trailing arm

The screw positions of the trailing arms at the wishbone bearing points may not be modified. The wheelbase on the left and right sides of the Car must be 2,460 mm +/-15 mm. The measuring points are the centres of the wheel hubs.

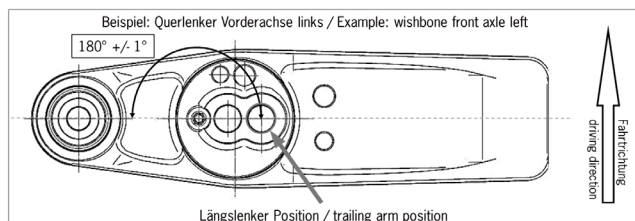

### 70.4. Anti-roll bars

The anti-roll bars are only allowed to be unhooked provided that no parts are removed in the process. Only the setting options for which the technical specifications have been provided are allowed to be used. Shims are allowed to be used to compensate for the axial clearance of the anti-roll bars on the front and rear axles. These are available in the following versions: 1 mm (991.343.761.8A) & 2 mm (991.343.761.8B).

Other shims or methods for axial clearance compensation must not be used. However, the overall axial clearance must not be less than 2 mm referred to each anti-roll bar.

### 70.5. Tie rods

The replacement of the inner Torx screw with part number 999.073.252.09 by an external hex screw with part number 900.378.103.01 is not subject to any restrictions.

## 70.6. Shock absorbers/springs

Only the factory-installed type Sachs shock absorbers and H&R chassis springs in their original condition are allowed to be used. The following number is stamped on the bump stops of the rear vibration dampers: 0049 5111 0 250. The original delivery condition of the bump stops of the front and rear dampers must not be modified in any way.

Vibration damper:	Front: 991.343.045.8D & Rear: 991.333.051.8A
Bump stop:	Front: 991.343.677.8A & Rear: 991.333.677.8A
Main spring:	Front: (240 N/mm): 991.343.531.8C & Rear: (260 N/mm): 991.333.531.8C
Helper spring:	Front: (75/60/45): 996.343.537.90 & Rear: (80/60/60): 997.333.537.90

## 71. Bodywork

### 71.1. General description

- Lightweight bodywork with smart aluminium-steel composite construction
- Welded-in roll cage certified in compliance with FIA homologation regulations for safety cages
- Front bonnet with 2 air inlets for cockpit ventilation and quick fasteners
- Removable rescue hatch in the roof
- Holder for recovery beam system same as DTM system
- Modified 911 GT3 wings with flared wheel arches
- Widened rear wheel arches
- Modified and widened 911 GT3 front apron with spoiler lip
- Modified GT3 rear apron with integrated rain light in compliance with FIA Homologation Regulations

### 71.2. Bodyshell protection

It is highly recommended to have the Car equipped with the protection plates for the rear cast aluminium sub frame (PPN: 9915803168A, 9915803158A, 9915803188A, 9915803178A)

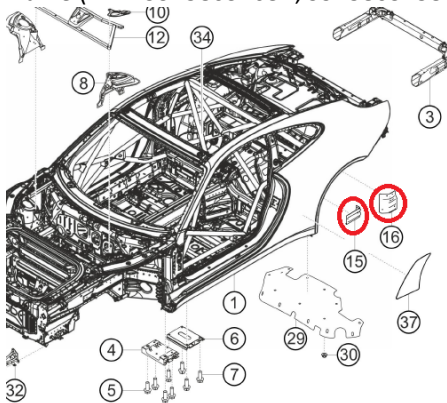

### 71.3. Lightweight exterior equipment

- CRP doors with Sport-Design rear-view mirrors
- CRP rear lid with quick-action fasteners
- CRP rear wing, adjustable
- PC rear side windows with ventilation openings
- PC rear window
- Underbody panelling with air routing for brake and driveshaft cooling on the rear

Door retaining bolts which are mounted in the door hinges can be changed by a non-Porsche genuine bolts. This should be a threaded bush bolt with a female 4mm Allen head M8x1x16. You can purchase this item from the Porsche Sprint Challenge Benelux Support team.



#### **71.4. Modified 911 cockpit**

- Weight-optimised magnesium subframe
- Ergonomic Driver-oriented centre console
- Trim for switches with fluorescent lettering
- Steering wheel with quick-release coupling, control panel and shift paddles
- Racing bucket seat with fore/aft adjustment:
- Homologation according to the latest FIA requirements
- Individual padding system
- 6-point seat belt
- 100-litre FIA FT3 – 1999 safety fuel tank
- 3-point air jack system
- Built-in air jack system (three jacks) with valve mountable on both sides of the Car

#### **71.5. Water-based paint**

- Exterior: white C9A
- Interior: white filler-coat, no clear-coat finish

#### **72. Overall Car dimensions and overhangs**

- The overall length of the Car is 4,547 mm +/-10 mm.
- Total width: 1,851 mm
- Total height: 1,280 mm
- Wheelbase: 2,460 mm +/-15 mm
- The front overhang is 1,043 mm +/-10 mm, measured from the middle of the wheel of the front axle to the leading edge of the Car (first point in the direction of the longitudinal axis, incl. front lip).
- The rear overhang is 1,045 mm +/-10 mm, measured from the middle of the wheel of the rear axle to the rear edge of the Car (last point in the direction of the longitudinal axis, rear wing excluded).

#### **73. External bodywork (including windows)**

The delivery status of the bodywork has to be preserved.

##### **73.1. Windscreen**

In addition to the original part, windscreens of the 911 GT3 Cup MY 2013-2017 with the part number 991.541.911.00 are allowed to be used, as well as windscreens of the Porsche 911 GT3 street Car with part number 9P1845011C. Heated windscreens with part number 991.541.111.8B are permitted. The windscreen is allowed to be connected to the electrical system of the Car and the heating function is allowed to be used. To protect the windscreen and as a safety measure, 'tear-off' screens are allowed to be attached to the windscreen. Fitting will be checked during Technical Scrutineering and must be removed where applicable on request of the Technical Scrutineers.

##### **73.2. Side and rear windows**

Only the genuine Porsche 911 GT3 Cup side and rear windows in their original version are permissible.

Door window: Left: 991.542.511.8B, 991.543.511.8C, 991.543.511.8F  
Right: 991.542.512.8B, 991.543.512.8C, 991.543.511.8F

Rear side window: Left: 991.543.511.8A & Right: 991.543.512.8A

Rear window: 991.545.111.8A

#### **74. Cockpit**

##### **74.1. Seat**

The adaption of the seat by removing or adding of original Recaro seat padding is forbidden in the areas of the seat shown in green colour on the illustration underneath. Any modification of the seat padding shown in green colour is strictly prohibited. The use of the different sizes paddings is allowed, also in the areas shown in green colour, as long as they are not modified. An upholstery in the bottom part of the seat on top of the paddings shown in green, as long as the original padding is not modified or removed. An upholstery of the areas shown in yellow colour is allowed by either using original Recaro paddings or using a foamed seat insert,

as long as the insert is made of fireproof material, coloured in black and its maximum thickness at any point does not exceed 50 mm in size. The use or change is subject to approval by the Series Organizer. The preferred supplier for padding components is the seat manufacturer (Recaro). The original seat mounting (seat rails and bracket) must be retained and must not be modified.

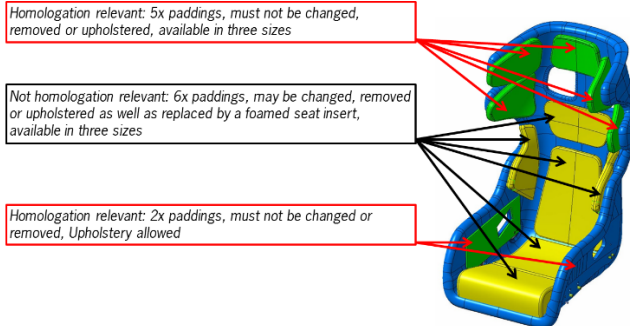

### 74.2. Safety Nets

It is mandatory to equip the Cup Car with the after sales safety net mounted on the left side of the Driver. As specified in the valid spare parts catalogue and mounted complying with the Porsche AG mounting instructions.

### 74.3. Roll cage safety padding

All Porsche GT3 Cup, type 991 Gen I Cars, must be equipped with the mandatory rollcage padding.

#### Y-rollcage:

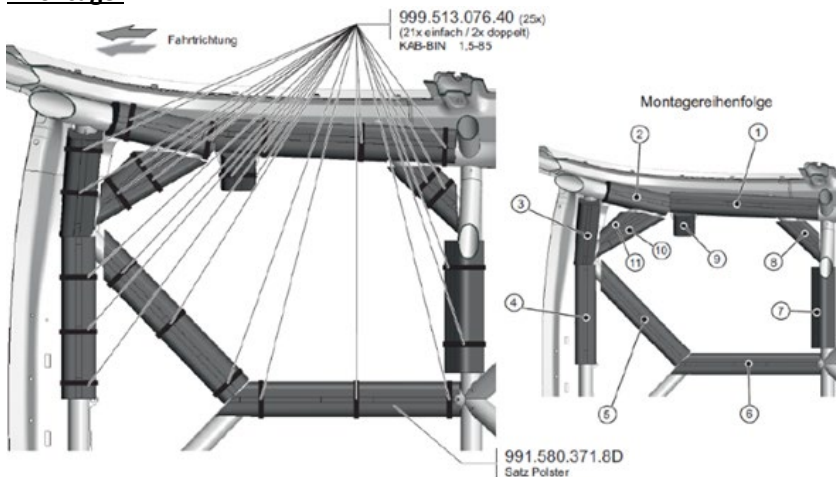

#### Diagonal-rollcage:

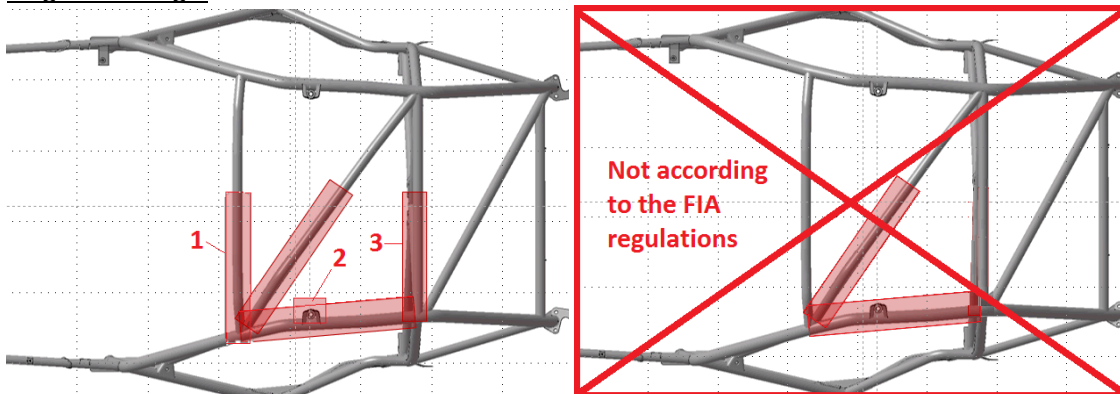

All Porsche GT3 Cup, type 991 Cars, must be equipped with the mandatory rollcage padding located in the Drivers footwell. (PPN.: 9F0.880.413)

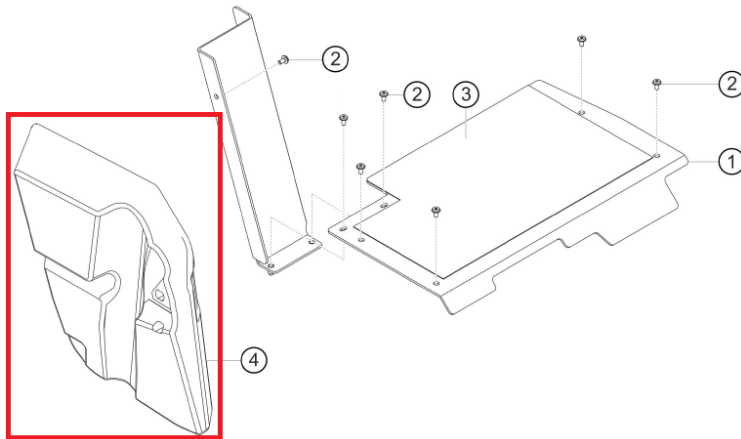

#### 74.4. Additional roof hatch accessories

The Car has an opening in the roof in order to make using the KED system easier should it become necessary to rescue the Driver. The roof hatch is located directly above the Driver and with the dimension of the opening 420 x 420 mm. The roof hatch is connected to the roof via 4 livelocks.

#### 75. Aerodynamic devices

The original position of the wing section is allowed to be changed within the specified scope for adjustment. Masking the central cooler in horizontal line to regulate the water temperature of the engine is allowed. Masking of the side radiators for additional control of the coolant temperature is only permitted if the centre radiator has already been completely masked. The masking shall be in black, starting from the top to the bottom. One strip of transparent adhesive tape (max. 80 mm long, 20 mm wide) is permitted as a fixing element on the headlights, the tail lights, the front wheel covers (9915053668AG2X and 9915053658AG2X), at a 90° angle in relation to the particular gaps that are taped over. Complete masking of the filler flap (99150303400GRV) is also approved. Furthermore, the teams are allowed to tape over the full area of the headlight lenses with transparent tape, without thereby taping over a slot in the bodywork. Apart from that, taping over of slots in the bodywork and openings is not allowed. If a session is declared as a wet session it is permitted to close all slots on the rear side window with transparent tape.

#### 76. Electrical equipment

##### 76.1. General description

- COSWORTH ICD colour display
- COSWORTH electrical system control unit IPS32
- Electronic accelerator pedal
- Fire extinguishing system (extinguishing agent: gas)
- 12 V, 70 Ah battery, leak-proof, placed in the passenger's footwell, mandatory OEM battery cover
- 150 A alternator
- Weight optimised fan
- Wiper with direct drive

##### 76.2. Lighting system

- Bi-Xenon headlights
- LED daytime driving lights
- LED rear lighting system and rain light

##### 76.3. Filter cable

All Porsche GT3 Cup, type 991 Gen I Cars must be equipped with the mandatory Filter cable.

PPN.:9916127638B

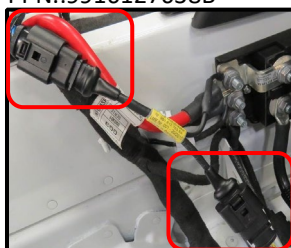

#### 76.4. Fire extinguisher system

All Porsche GT3 Cup, type 991 Gen I Cars' fire extinguisher system must be modified to the latest spec.

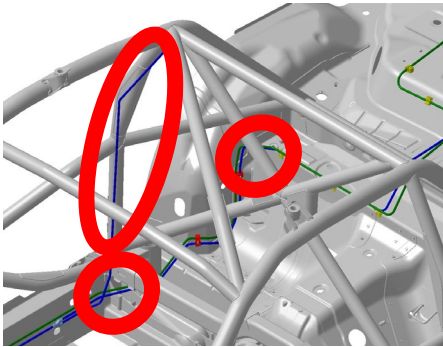

#### 77. Fuel circuit

Only the fuel system permitted for the Porsche 911 GT3 Cup Cars of model years 2016, 2015 and 2014 is allowed to be installed. In addition, the in-tank wiring harness of model year 2013 with part numbers 991.201.697.8A or alternatively 991.201.697.8J is allowed to be used. Additionally, to the original fuel system, every Car can be equipped with the after sales defueling appliance consisting of the following parts:

- breakaway coupling: 2x 9971101918C
- sealing washer: 2x 9912018839A
- support washer: 2x WHT004800
- adapter piece: 1x 9F0201156
- drain hose: 1x 9F0201627
- clamp: 1x 90017101401

The running of the Car using the service position of the fuel pumps is prohibited, as long as there is no technical issue with the system. The system may not be used with any of the pumps switched to service position for more than one lap.

#### 78. Optional parts

All parts found in the parts catalogue, from the eligible Car, as indicated as an option are allowed to be used. Including endurance parts that aren't permitted in a regular Porsche One-Make-Serie.

#### 79. Lubrication system

Engine: MOBIL1, 0W40 engine oil mandatory. All additives are prohibited.  
Transmission: Mobilube, 1SHC 75W-90 transmission oil is mandatory. All additives are prohibited.  
There has to be min 2.7 liters transmission oil in the gearbox at all times during the Event.

## Part C4: Specific Tech. Regulation according to the Porsche 718 Cayman GT4 RS Clubsport (MY 2021 – 2024)

#### 80. General information

Technically identical cars with the designation Porsche 718 Cayman GT4 RS CS Type (982), built by Dr. Ing. h.c. F. Porsche AG in a small production run based on the Porsche Cayman GT4 RS, shall be used for the event. Only cars of model year from 2021-2024 (982) see following general car description are permitted.

#### 81. Engine

##### 81.1. Engine electronic control units

Throughout the entire event, only the electronic control units in original conditions are permitted to be used. The engine electronic control unit incl. the complete wiring harness must be used without modifications. The event organizer or the Technical Scrutineers reserve(s) the right to check or exchange the engine electronic control unit or record the engine characteristic data at any time during the event.

## **82. Exhaust system**

Like in the general car description (see Part C.1. Item 1.1), it is only allowed to use the original exhaust system, starting from the manifold, exhaust pipes, the catalytic converters and the muffler. It is not allowed to modify any of these parts.

- Manifold: 9F2254450/ 00
- Exhaust pipes incl. Catalytic converters: 9F2.254.351C
- Muffler: 50C 9F2.251.052 / 53C

### **82.1. General description**

- Aluminium six-cylinder mid-mounted boxer engine
- 3,996 cm<sup>3</sup>; stroke 81,5 mm; bore 102 mm Max. rpm: 8750 rpm
- Dual-mass flywheel
- Water cooling with heat management for engine and gearbox
- Direct fuel injection
- Required fuel quality: minimum 98 octane, unleaded max. E10
- Electronic engine management

Any work on the engine that requires the seal to be opened is only permitted to be undertaken at Dr. Ing. h.c. F. Porsche AG. An engine change has to be approved in writing by the event organizer prior to the change.

Engines can be called in and inspected at the instructions of the Stewards.

### **82.2. Exception**

For event days at the TT circuit Assen it is obliged to install extra rear dampers with part nr. PSC718CSRS007. These parts are obtainable by the organizer of the event. (see page 14 3.0 Source of spare parts catalogues for contact details) (Attachment 4 extra dampers)

## **83. Power transmission (Gearbox/Differential Lock)**

- Porsche 7-speed PDK gearbox
- Internal pressure-oil lubrication with active oil cooling
- Mechanical differential lock optimized for motorsports (Ramp angles: ACCEL 50°/DECCEL 35°)

The number of friction plates and the assembly order shall correspond to the specification in the Technical Manual and must not be changed.

## **84. Lubrication system**

### **Lubricants**

No less than the minimum quantity of lubricants in the engine and gearbox as specified in the Technical Manual must be used at all times during any event.

The addition of any additives or any chemical changes to the lubricants are prohibited.

### **Engine:**

Mobil 1 ESP X3 0W-40 engine oil is compulsory.

### **Transmission:**

Mobilube 1 PTX 75W-90 transmission oil is compulsory. Pentosin FFI 3 clutch oil is compulsory.

## **85. Brakes**

It is not permitted to modify the car to endurance brake calipers, even if they might be listed in the parts catalogue.

### **85.1. General description**

- Two independent brake circuits adjustable by the driver via brake balance system.
- Front axle:
  - Six-piston aluminium racing calipers in mono-bloc design with "anti-knock-back" piston springs
  - Ventilated and grooved steel brake disc 380 mm diameter with aluminium disc bell o Racing brake pads
- Rear axle:

- Four-piston aluminium racing calipers in mono-bloc design with "anti-knock-back" piston springs
- Ventilated and grooved steel brake disc 380 mm diameter with aluminium disc bell
- Racing brake pads

Only standard master brake cylinders are permitted for the 2 brake circuits on the

- Front axle diameter: 17.8 mm
- Rear axle diameter: 17.8 mm

A knock-back spring must be installed in each case under each brake piston of all brake calipers. External thermal or chemical treatment of these springs is prohibited.

## **86. Wheel Suspension**

### **86.1. General description front axle**

- McPherson suspension strut, adjustable in height, wheel camber and track
- Double shear track rod connection
- Heavy-duty spherical bearings
- Racing shock absorbers
- Forged & adjustable top mounts
- Double-blade-type adjustable anti-roll bar
- Electrohydraulic power steering with variable steering ratio
- Tire pressure monitoring system

### **86.2. General description rear axle**

- Multilink rear suspension, adjustable in height, wheel camber and track
- Double shear track rod connection
- Racing shock absorbers
- Double-blade-type adjustable anti-roll bar
- Tire pressure monitoring system

### **86.3. Allowed adjustments**

The suspension is permitted to be modified within the scope of the specified setting range. All genuine parts must be retained. The maximum permissible combined thickness of the spacer washers in the front and rear axle control arms are:

- Front axle: 18.0 mm
- Rear axle: 18.0 mm

With an exception for Zandvoort. Front axle can be max. 18 mm and rear axle 10 mm.

A change to the maximum permissible combined thickness of the spacer washers in the front and rear axle control arms and/or camber values can be announced by Stewards' bulletin at any time before or during any event.

It is permitted to fix the camber shims in position with aluminium tape.

All bearing points of the front and rear control arms must be left in the position in which they are delivered.

The wheelbase on the left and right sides of the car must be 2,476 mm +/-10 mm.

The measuring points are the centres of the wheel hubs.

### **86.4. Anti-roll bars**

The anti-roll bars are only permitted to be unhooked provided that one coupling rod of the respective rollbar is completely removed. Only the respective setting options given in the Technical Manual are permitted to be used.

### **86.5. Shock absorbers/springs**

Only the factory-installed type KW shock absorbers and KW chassis springs in their original condition are permitted to be used. The original delivery condition of the bump stops must not be modified in any way.

## **87. Ballast**

The installation of original Dr. Ing. h.c. F. Porsche AG ballast weights is permitted on the auxiliary weight base plate at the position of the passenger's seat in accordance with the illustration in Attachment 3. The ballast weights are identified by spare part numbers in the spare parts catalogue. No other ballast weights or locations are permitted. The mounting of the ballast base plate (Pn.: 9815048478A or 9915048477B) and the ballast cover (Pn.: 9915048657A) are mandatory.

If the original base plate does not contain the necessary holes for the mounting positions as indicated in these regulations, they can be added after consultation with the Technical Scrutineers. The mounting holes can only be added in the necessary positions to satisfy the requirements of these regulations.

## **88. Bodywork and dimensions**

### **88.1. General description**

- Lightweight bodywork with smart aluminium-steel composite construction
- Integrated (welded) roll cage, in compliance with FIA homologation regulations for safety cages
- Front bonnet with quick release fasteners, air duct for brake cooling
- Removable rescue hatch in compliance with the latest FIA safety regulations
- Pre-equipped fixation point for center safety net attachment
- Lightweight exterior:
  - Flax composite-reinforced plastic doors with sport-design rear-view mirrors
  - Carbon-fibre-reinforced plastic adjustable rear wing (7 positions)
  - Polycarbonate door windows
- Rear underfloor with NACA ducts for brake and driveshaft cooling

### **Modified 718 GT4 Cockpit**

- Ergonomic driver-oriented center console
- Steering wheel with quick release coupling, control panel and shift paddles
- Adjustable steering column with steering angle sensor
- Race bucket seat with longitudinal adjustment
- Homologated to latest FIA requirements
- Individual padding system
- Shock absorbing roll cage safety cover for leg protection at driver's foot well
- Six-point racing safety harness
- Built-in air jack system (three jacks) with valve mountable on both sides of the car

### **88.2. Overall car dimensions and overhangs:**

The overall length of the car is 4,458 mm +/- 10 mm.

Total width: 1,817 mm

The wheelbase of the car is 2,476.0 mm +/-10 mm, measured at the centres of the wheel hubs.

The front overhang is 1,070 mm +/-10 mm, measured from the middle of the wheel of the front axle to the leading edge of the car (first point in the direction of the longitudinal axis, including front lip).

The rear overhang is 912 mm +/-10 mm, measured from the middle of the wheel of the rear axle to the rear edge of the car (last point in the direction of the longitudinal axis, including the exhaust, rear wing excluded).

### **88.3. External bodywork (including windows)**

The delivery status of the bodywork must be preserved.

### **88.4. Windscreen**

To protect the windscreen and as a safety measure, 'tear-off' screens are permitted to be attached to the windscreen. Fitting will be checked during Technical Scrutineering and must be removed where applicable on request of the Technical Scrutineers.

### **88.5. Rear window**

Only the genuine Porsche Cayman GT4 RS rear window in their original version are permissible. Additionally, the rear window must remain fixed with the original type of fixing at all times.

## **89. Cockpit**

### **89.1. Seat**

The adaptation of the seat by removing or adding of original Recaro seat padding is forbidden in the areas of the seat shown in green colour on the illustration of Attachment 3. Only the substitution of original unmodified padding by another original unmodified padding in a different size is permitted.

Upholstery in the bottom part of the seat on top of the paddings shown in green (see illustration in Attachment 3) is permitted, as long as the original padding is not modified or removed.

The areas shown in yellow colour on the illustration of Attachment 3 may be changed, removed or upholstered. Upholstery is permitted by using original Recaro paddings (with a maximum thickness at any point not exceeding 50 mm).

A foamed seat insert, according to FIA Appendix J, Article 253-16, may be used as long as the insert is made of fireproof material, coloured in black. For further components (seat shells, seat paddings, seat insert etc.) that are subsequently installed within the applicable FIA regulations, a proof must be provided to the organizer during technical scrutineering upon request.

The use or change is subject to approval by the Series Organizer/Technical Scrutineers.

The provisions of FIA International Sporting Code Appendix J Article 253-16 must be complied with all the times.

The preferred supplier for padding components is the seat manufacturer (Recaro).

The original seat mounting (seat rails and bracket) must be retained and must not be modified.

### **89.2. Safety nets**

Every car must be equipped with safety nets mounted in compliance with the official Dr. Ing. h.c. F. Porsche AG mounting instructions.

### **89.3. Additional roof hatch accessories**

The car has a roof hatch (to facilitate Driver extraction) which is connected to the roof via 7 liveness and which must be accessible at all times (no foiling or painting of live locks is permitted).

## **90. Aerodynamic Devices**

The original position of the wing section is permitted to be changed within the specified scope for adjustment provided by the Technical Manual.

It is permitted to tape over the full area of the headlight lenses with transparent Heli tape.

Taping over of any slots in the bodywork, wings or other permanent parts, joints and openings is not permitted.

Any alteration or amendment outside the above set parameters will render the car non-compliant with the Technical Regulations and may be subject to penalties from the Stewards.

## **91. Electrical equipment**

### **91.1. General description**

- COSWORTH colour display ICD with integrated fault diagnosis
- Electronic throttle system
- Fire extinguishing system (extinguishing agent: FE36 and NOVEC gas)
- Lightweight 12 V, 60 Ah battery (LiFePO4) leak-proof, placed in the co-driver foot well
- Alternator 175 A

- Lighting system:
  - LED daytime running light
  - LED rear lighting system and rain light in compliance with the latest FIA Homologation
- Regulation

CAN connection (data logger, video system)

Optionally, the usage of the following electrical equipment is permitted:

- Charging cable (1x 9F0051763B).

It is not permitted at any time for any competitor to read any sensors, with any equipment, which are not allocated to the competitor's own team. Any competitor breaching this regulation may be disqualified from the relevant session, race, or competition.

## 92. Fuel Circuit

Only the fuel system permitted for the Porsche 718 Cayman GT4 RS CS car of model year 2020 and 2024, is permitted to be installed.

Only original parts specified in the Porsche Motorsport and/or Manthey Racing catalogue can be used.

### 92.1. 'Trophy' specifications tank plate (fuel gun)

This system developed for refuelling with fuel gun or dumping barrels. The tank refuelling plate for fuel gun use must be installed with the bonnet with rounded whole, finished with carbon fibre ring.

- 'Trophy' spec refuelling plate: MTHPN.: MTH201615
- Bonnet made of sheet metal, with round hole: MTHPN.: MTH823310

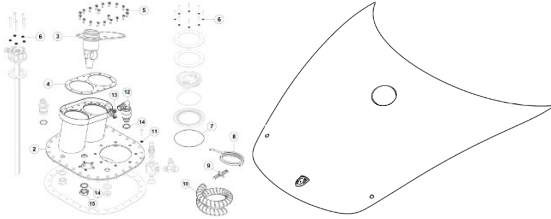

Attachment 1: Ballast weights

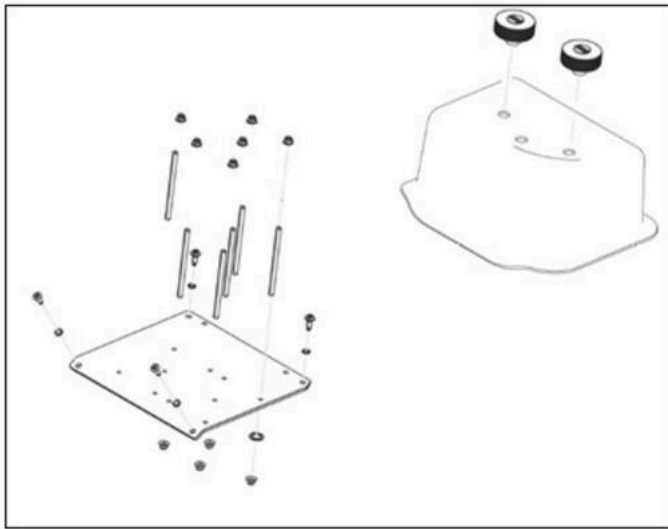
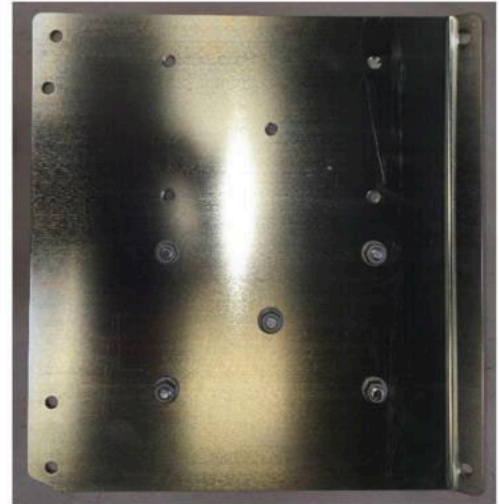
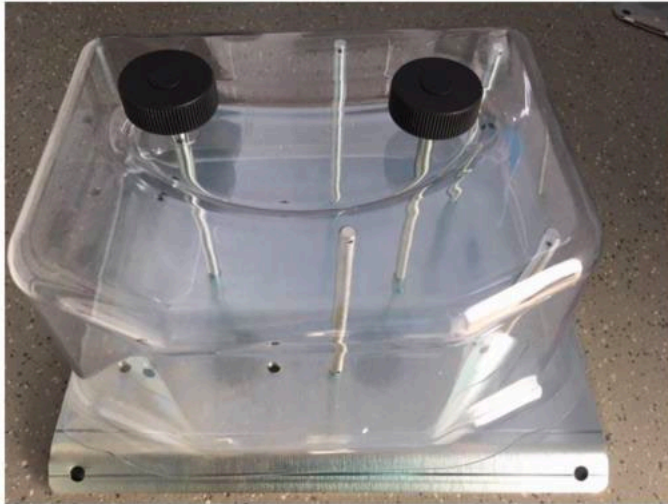

Attachment 2: Minimum Ground Clearance GT4 RS Clubsport

Front Axle



Front ground clearance: 78mm

Rear Axle

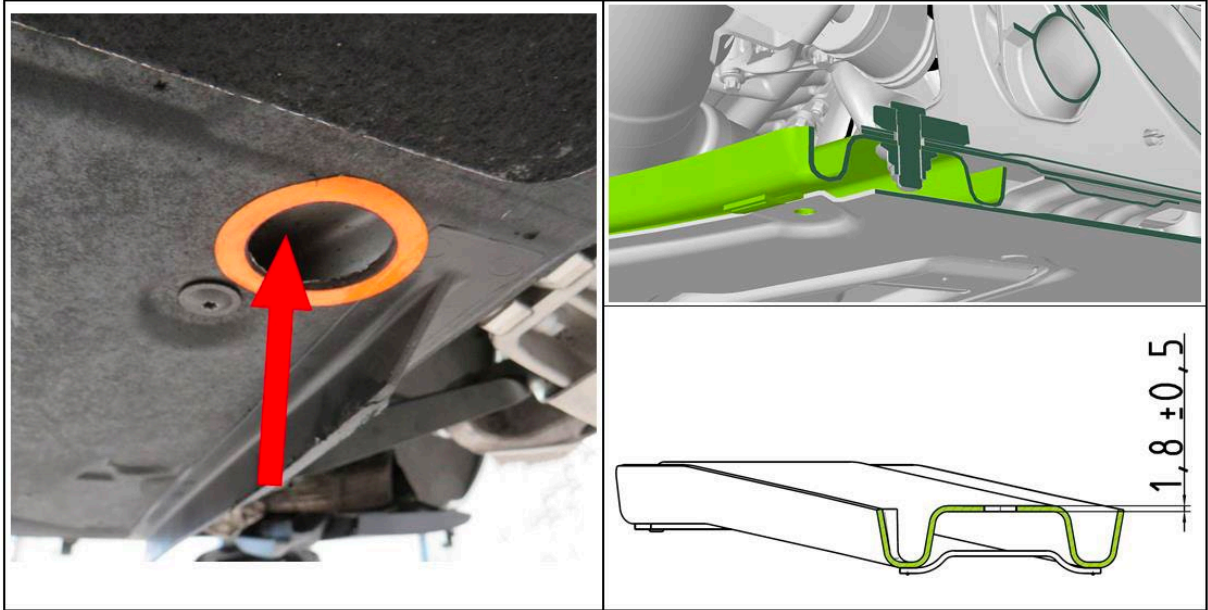

Rear ground clearance: 100mm

Attachment 3: Seat Padding

Homologation relevant: 5x paddings, must not be changed, removed or upholstered, available in three sizes

Not homologation relevant: 6x paddings, may be changed, removed or upholstered as well as replaced by a foamed seat insert, available in three sizes

Homologation relevant: 2x paddings, must not be changed or removed, Upholstery allowed

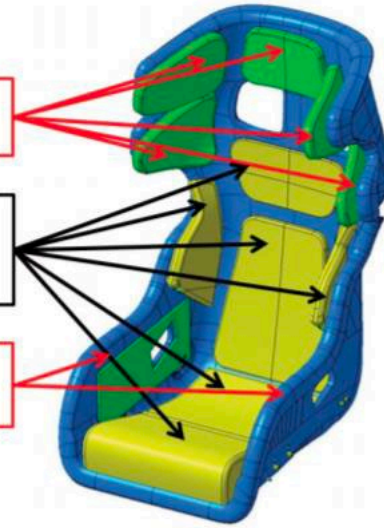

Attachment 4: Extra silencers.



## Part C5: Specific Tech. Regulation according to the model Porsche 718 Cayman GT4 MR Clubsport, Type 982, ('19-'20)

According to the GT4 Homologation of the Car, with the exceptions mentioned in these technical regulations:

- Tyres
- Min. ground clearance
- Min. Car weight
- Max. camber shims

Cars may be equipped with or without the side air intake at the rear side windows.

Cars without this air intake may participate in the GT4 or GT4 – AM class. Cars with intake participate in the GT4 RS class.

## Part C6: Specific Tech. Regulation according to the model Porsche 718 Cayman GT4 Clubsport, 'Trophy'-spec, Type 982, ( '19-'20)

### 93. General Car description

Porsche 718 Cayman GT4 Clubsport (type 982), MY 2019

Concept: Single-seater, near-standard production-based race Car, not road homologated.  
Based on the Porsche Cayman GT4

### 94. Engine

- Aluminium six-cylinder rear-mounted boxer engine with rigid mounting
- 3,800 cc; stroke 76.4 mm, bore 102,7 mm
- Max. power: 313 kW (425 hp) at 7,500 rpm
- Max. rpm: 7,800 rpm
- Max. torque: 425 Nm at 6 600 rpm
- Compression ratio: 12.5:1
- Racing optimised water cooling with thermal management for engine and gearbox
- Four-valve tech., adjustable camshaft phasing, variable valve timing VarioCam Plus
- Sequential multi-point fuel injection
- Fuel quality: minimum 98 octane, unleaded
- Dry sump lubrication
- Electronic engine management (Continental SDI 9)
- 100-cell metal catalytic converter complying with DMSB specifications
- Rear silencer with central tailpipes
- Variable intake system with adjustable resonance butterflies
- Twin pipes sport exhaust system featuring two central tailpipes

### 95. Power transmission (gearbox/differential lock)

- Rear wheel drive
- Rigidly mounted Porsche six-speed PDK- gearbox (DCT, dual clutch transmission)
- Limited slip differential optimised for racing
- Dual mass flywheel

Obligatory 10mm spacers must be installed between the transmission and the drive shaft flanges in conjunction with mandatory mounting material.

- |                                 |                   |
|---------------------------------|-------------------|
| • Spacer sleeve                 | PPN.: 9F2501199   |
| • Plate link shaft              | PPN.: 9P1501375   |
| • ZYL-SHR M10x55 4762 12.9 B110 | PPN.: 90006708701 |

## 96. Brakes

### Front axle:

- Six-piston aluminium racing brake calipers in mono-bloc design with “anti-knock-back” piston springs
- Ventilated and grooved steel brake disc 380 mm diameter with aluminium disc bells  
PPN.: 9F2615283 (FL) PPN.: 9F2615284 (FR)
- Racing brake pads  
PPN.: 9913519428B (Endurance)
- Optimized brake cooling duct layout

### Rear axle:

- Four-piston aluminium racing brake calipers in mono-bloc design with “anti-knock-back” piston springs
- Ventilated and grooved steel brake disc 380 mm diameter with aluminium disc bell  
PPN.: 9F2615583 (RL) PPN.: 9F2615584 (RR)
- Racing brake pads  
PPN.: 9F2615117A (Endurance)
- Optimized brake cooling duct layout

A knock-back spring must be installed in each case under each brake piston of all brake calipers. External thermal or chemical treatment of these springs is prohibited.

PPN.: 9913519638A (Front) PPN.: 9913529638A (Rear)

The integrated driving stability system PSM (includes ESC and TC) is specially set up for use on the track and must not be changed by the Competitor. The system can be fully switched off.

## 97. Steering (steering wheel/hub extension)

Steering is defined in the parts catalogue and must be assembled without any changes.

## 98. Wheel suspension

### 98.1. General description front axle

- McPherson suspension strut, adjustable in height, wheel camber and track
- Forged suspension links:
  - Optimised stiffness
  - Double shear mounting
  - High-performance spherical bearings
- 5 bolt wheel hubs
- Racing shock absorbers, non-adjustable
- Reinforced track rods
- Electromechanical power steering with variable steering ratio
- Anti-roll bar, 3-hole design

### 98.2. General description rear axle

- McPherson suspension strut
- Forged suspension links: Optimised stiffness, double shear mounting, high-performance spherical bearings
- 5 bolt wheel hubs
- Racing shock absorbers, non-adjustable
- Adjustable blade-type anti-roll bar

### 98.3. Wheelbase

The trailing arm axle bearing points of the front and rear control arms must be left in the position in which they are delivered. Additionally, the screw positions of the trailing arms at the wishbone bearing points may not be modified. The wheelbase on the left and right sides of the Car must be 2472 mm (+/-15 mm). The measuring points are the centres of the wheel hubs.

### 98.4. Anti-roll bars

The anti-roll bars are allowed to be unhooked, for this purpose the stabiliser link that is unhooked must be removed. Only the setting options for which the technical specifications have been provided are allowed to be used.

### 98.5. Shock absorbers/springs

Only the following combinations are allowed. Spring combinations may only be completely installed as stated underneath. Standard spring combination (130 / 150N / mm) must not be combined with strut combination option 1 (110 / 120N / mm).

'Trackday' specifications – STANDARD (Porsche Motorsport)			
Front		Rear	
Shock absorber	9F2412019	Shock absorber	9F2512019
Main spring 130-140	9F2411105	Main spring 150-170	9F2511121
Auxiliary spring 10-60-80	9813435378A	Auxiliary spring 10-60-80	9813435378A

'Competition' specifications – STANDARD (Porsche Motorsport)			
Front		Rear	
Shock absorber	9F241202(3/4)A	Shock absorber	9F2512020A
Main spring	9F2411105A	Main spring	9F2511121A
Auxiliary spring	9813435378A	Auxiliary spring	9813435378A

'Trackday' specifications – OPTION 1 (Manthey Racing)			
Front		Rear	
Shock absorber	9F2412019	Shock absorber	9F2512019
Main spring 110-140	MTH343533	Main spring 120-170	MTH333533A
Aux. spring 10-60-80	MTH343538	Aux. spring 3-60-80	MTH343537A
Bump stop	65210488	Bump stop kit	MTH072300

## 99. Bodywork

### 99.1. General description

- Lightweight bodywork with intelligent aluminium-steel composite construction
- Welded-in roll cage, in compliance with FIA Homologation Regulations for safety cages
- Front bonnet with quick release fasteners
- Rear deck with quick release fasteners
- Fixed rear wing with "swan neck" mount made of natural-fibre composite materials, including the side blades, black aluminium wing supports with integrated carbon fibre Gurney flap
- Six-point safety harness
- Driver and co-Driver doors of natural-fibre composite materials
- Roof including escape hatch, certified according to FIA Art. Appendix 275a
- Provision for safety net
- FIA certified towing loops
- Three-piston air jack
- Recaro race bucket seat with longitudinal adjustment and padding system, adjustable to the individual needs of the Drivers (in accordance with FIA Standard 8862/2009 – the latest FIA requirements)
- Motorsport centre console with enhanced functionality and adapted usability
- 115 liter FT 3 Safety cell with 'Fuel cut off' safety valve according FIA

### 99.2. External Bodywork (including Windows)

The windows of the Driver and passenger door, the rear side windows and the rear window must be covered with safety foil as described in the parts catalogue and the user manual.

The outside of the windscreen may also be covered with a clear safety film/rip-off film (not coloured). The laminated glass front windscreen may optionally be replaced by a polycarbonate windscreen.

MTHPN.: MTH541911

In general, it is not permitted to close or glue openings or joints. In the case of provisional repairs during the Event, joints or openings in the direct vicinity of the damage may be covered with adhesive tape if this is necessary due to a lack of time. The technical delegate will decide on whether the repairs are permissible.

### **99.3. Cockpit**

No individual ventilation hoses are permitted. A drinks unit may be fitted if this is a permanent attachment and the mounting points can withstand an acceleration of up to 25G. It is at the technical delegate's discretion to assess whether he believes the attachment used is sufficient. The pedals may not be changed. This does not include adding a film with increased friction. The seat, seat rails and belts must correspond to the parts catalogue. The series steering column adjustment mechanism is maintained. All covers in the cockpit must be used as described in the parts catalogue.

### **100. Ballast**

The installation of original Dr. Ing. h.c. F. Porsche AG ballast weights is permitted on the auxiliary weight base plate at the position of the passenger's seat in accordance with the illustration in Attachment 3. The ballast weights are identified by spare part numbers in the spare parts catalogue. No other ballast weights or locations are permitted. The mounting of the ballast base plate (Pn.: 9815048478A or 9915048477B) and the ballast cover (Pn.: 9915048657A) are mandatory.

If the original base plate does not contain the necessary holes for the mounting positions as indicated in these regulations, they can be added after consultation with the Technical Scrutineers. The mounting holes can only be added in the necessary positions to satisfy the requirements of these regulations.

#### ***Auxiliary weights part numbers:***

<b>Part</b>	<b>Part number</b>
<b>AUXILIARY WEIGHT 2KG/6MM</b>	<b>9F1801141</b>
<b>AUXILIARY WEIGHT 3,4KG/10MM</b>	<b>9F1801141A</b>
<b>AUXILIARY WEIGHT 6,8KG/20MM</b>	<b>99150484802</b>
<b>COVERING AUXILIARY WEIGHT</b>	<b>9915048657A</b>
<b>NUT FOR COVER</b>	<b>WHS001903</b>

### **101. Electrical Equipment**

The Cayman GT4 Clubsport has a tyre pressure system (RDK) as a standard feature. It is mandatory to use the RDK sensors during the Event. If the race organizer should require additional systems that result in data transfer, this must be approved by the technical delegate. Only the sensors described in the parts catalogue may be used.

#### **Optional systems:**

Additional lighting kit	MTHPN.:	TBA
Charging cable	PPN.:	9F0051763B
Voltage supply electronic	PPN.:	9816106898A

### **102. Air Jack System**

The air lifting system including the air lance system is mandatory. MTHPN.: MTH583004A

The positions of all the components that are relevant for the system, such as the air lance connector mounted on the Car, may not be changed. In addition, regulations stipulate that, after the air lance is removed from the air lance connector, the pressure must remain in the lifting system. Only the operation of the valve mounted on the Car must lead to air being released and the jacks being pulled-in.

### **103. Water-based paint**

- Exterior: white C9A
- Interior: white filler-coat, no clear-coat finish

### **104. Overall Car dimensions and overhangs**

- The overall length of the Car is 4456mm.

- Total width: 1778 mm
- Total height: 1238 mm
- Wheelbase: 2,472 mm +/-15 mm

### **105. Lubrication system**

Engine: Mobil 1 ESP X4 0W-40  
 Transmission: Clutch oil (ATF): Pentosin FFI 3  
 Final drive: 75 W 90 Mobilube PTX

The above mentioned oil types are mandatory. All additives are prohibited.

### **106. Fuel system**

A safety fuel tank according to FIA standard FT3-1999 by Art. 253.14 is installed. The maximum fuel volume of 115 litres is made up of the internal volume of all fuel-carrying components, including e.g. the filler pipe or the filler neck. Only the participant is responsible for ensuring that the maximum permitted volume is not exceeded. It is permitted to reduce the volume of the fuel tank using volume displacers/displacement balls. Two different refuelling systems are allowed. One of those two system must be installed. Only original parts specified in the Porsche Motorsport and/or Manthey Racing catalogue can be used.

#### **106.1. 'Trophy' specifications tank plate (fuel gun)**

This system developed for refuelling with fuel gun or dumping barrels. The tank refuelling plate for fuel gun use must be installed with the bonnet with rounded whole, finished with carbon fibre ring.

- 'Trophy' spec refuelling plate: MTHPN.: MTH201615
- Bonnet made of sheet metal, with round hole: MTHPN.: MTH823310

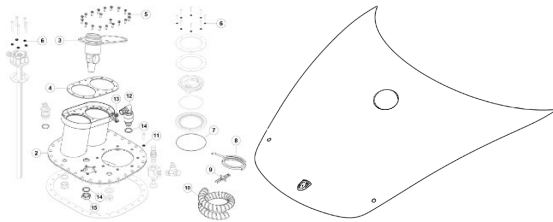

### **107. Mandatory rework**

#### **107.1. Engine air ducts mesh:**

To protect the two engine air ducts and the engine compartment ventilation system from sucking debris, the installation of the protection meshes into the air intakes in the body sills is mandatory.

MTHPN.: MTH541561 (Left)

MTHPN.: MTH541562 (Right)

#### **107.2. Safety nets:**

It is mandatory to use the after sales safety nets as specified in the valid spare parts catalogue and mounted complying with the Porsche AG mounting instructions.

MTHPN.: MTH801110

#### **107.3. Safety foam Driver's door:**

It is mandatory to use the after sales safety foam mounted in the Driver's door as specified in the valid spare parts catalogue and mounted complying with mounting instructions.

MTHPN.: MTH531750

#### **107.4. Brake pressure switch:**

Valid for all Type 982 including the 'GT4'-spec. The brake pressure switch mounted on the front axle brake master cylinder must be changed to the latest spec. PPN: 9F1907457

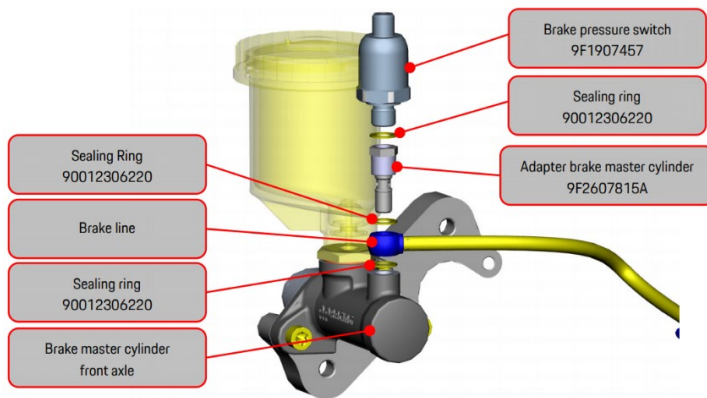

### 107.5. Roll over valve

Valid for all Type 982 including the 'GT4'-spec. The rollover valve mounted on the fuel tank must be changed to the latest spec. PPN: 9F0201741G

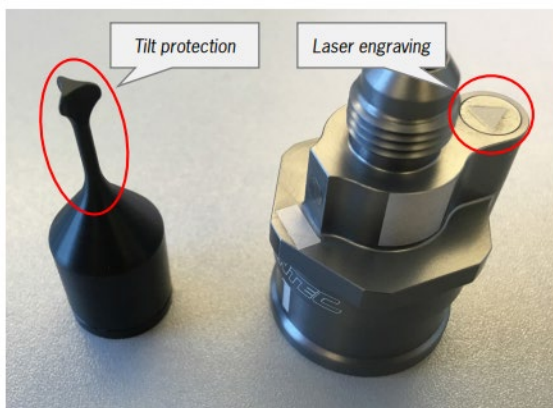

Fig. 3. New design floater with tilt protection and ROV housing upper part

## Part C7: Specific Tech. Regulation according to the model Porsche Cayman GT4 Clubsport, 'Trophy'-spec, Type 981, ('16)

### 108. General Car description

Porsche Cayman GT4 Clubsport (type 981), MY 2016

Concept: Single-seated, production-based race Car. Based on the Porsche Cayman GT4

### 109. Engine

- Aluminium six-cylinder rear-mounted boxer engine with rigid mounting

### 110. Power transmission (gearbox/differential lock)

- Rear wheel drive
- Rigidly mounted Porsche six-speed PDK- gearbox (DCT, dual clutch transmission)
- Limited slip differential optimised for racing
- Dual mass flywheel

### 111. Brakes

#### Front axle:

- Six-piston aluminium racing brake calipers in mono-bloc design with "anti-knock-back" piston springs
- Ventilated and grooved steel brake disc 380 mm diameter with aluminium disc bells  
PPN.: 9813511058A (FL) PPN.: 9813511068A (FR)
- Racing brake pads  
PPN.: 9913519428B (Endurance)
- Optimized brake cooling duct layout

**Rear axle:**

- Four-piston aluminium racing brake calipers in mono-bloc design with “anti-knock-back” piston springs
- Ventilated and grooved steel brake disc 380 mm diameter with aluminium disc bell  
PPN.: 9813521078A (RL) PPN.: 9813521088A (RR)
- Racing brake pads  
PPN.: 9913529428B (Endurance)
- Optimized brake cooling duct layout

A knock-back spring must be installed in each case under each brake piston of all brake calipers. External thermal or chemical treatment of these springs is prohibited.

PPN.: 9913519638A (Front) PPN.: 9913529638A (Rear)

The integrated driving stability system PSM (includes ESC and TC) is specially set up for use on the track and must not be changed by the Competitor. The system can be fully switched off.

**112. Steering (steering wheel/hub extension)**

Steering is defined in the parts catalogue and must be assembled without any changes. To improve the reach of the steering wheel for Drivers of differing tallness, there is the possibility to optionally fit a 40 mm steering wheel hub extension.

Steering wheel hub extension 40mm MTHPN.: MTH347810

(ref.: Manthey Racing Spare Parts catalogue Cayman GT4 CS Spec Trophy)

**113. Wheel suspension**

**113.1. General description front axle**

- McPherson suspension strut, adjustable in height, wheel camber and track
- Forged suspension links:
  - Optimised stiffness
  - Double shear mounting
  - High-performance spherical bearings
- 5 bolt wheel hubs
- Racing shock absorbers, non-adjustable
- Reinforced track rods
- Electrohydraulic power steering with variable steering ratio and steering impulse
- Modified anti-roll bar

**113.2. General description rear axle**

- McPherson suspension strut: Forged suspension links, Optimised stiffness, Double shear mounting, High-performance spherical bearings
- 5 bolt wheel hubs
- Racing shock absorbers, non-adjustable

**113.3. Wheelbase:**

The trailing arm axle bearing points of the front and rear control arms must be left in the position in which they are delivered. Additionally, the screw positions of the trailing arms at the wishbone bearing points may not be modified. The wheelbase on the left and right sides of the Car must be 2476 mm (+/-15 mm). The measuring points are the centres of the wheel hubs.

**113.4. Anti-roll bars**

The anti-roll bars are allowed to be unhooked, for this purpose the stabiliser link that is unhooked must be removed. Only the setting options for which the technical specifications have been provided are allowed to be used.

**113.5. Shock absorbers/springs**

Only the following combinations are allowed. Spring combinations may only be completely installed as stated underneath.

<b>'Trackday' specifications – STANDARD (Porsche Motorsport)</b>			
Front		Rear	
Shock absorber	9813430458A	Shock absorber	9813330458A
Main spring	9813435318A	Main spring	9813335318A
Auxiliary spring	9813435378A	Auxiliary spring	9813435378A
<b>'Trophy' specifications – STANDARD (Manthey Racing)</b>			
Front left	Front right	Rear	

Shock absorber	MTH343045	Shock absorber	MTH343046	Shock absorber	MTH333051
Main spring 140-140	MTH343531	Main spring 140-140	MTH343531	Main spring 150-140	MTH333531
Aux. spring 10-60-80	MTH343538	Aux. spring 10-60-80	MTH343538	Aux. spring 10-60-80	MTH343538
Bump stop	65210488	Bump stop	65210488	Bump stop kit	MTH072300
<b>'Trophy' specifications - OPTION 1 (Manthey Racing)</b>					
Front left		Front right		Rear	
Shock absorber	MTH343045	Shock absorber	MTH343046	Shock absorber	MTH333051
Main spring 140-140	MTH343531	Main spring 140-140	MTH343531	Main spring 150-170	MTH333532
Aux. spring 10-60-80	MTH343538	Aux. spring 10-60-80	MTH343538	Aux. spring 3-60-80	MTH343537A
Bump stop	65210488	Bump stop	65210488	Bump stop kit	MTH072300
<b>'Trophy' specifications – OPTION 2 (Manthey Racing)</b>					
Front left		Front right		Rear	
Shock absorber	MTH343045	Shock absorber	MTH343046	Shock absorber	MTH333051
Main spring 110-140	MTH343533	Main spring 110-140	MTH343533	Main spring 120-170	MTH333533A
Aux. spring 10-60-80	MTH343538	Aux. spring 10-60-80	MTH343538	Aux. spring 3-60-80	MTH343537A
Bump stop	65210488	Bump stop	65210488	Bump stop kit	MTH072300

Front - bump stop: MTHPN.: 652 10 488

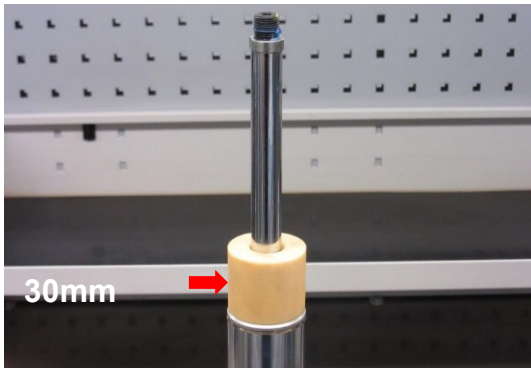

Rear: Packer / Bump-Stop Kit MTHPN.: MTH072300

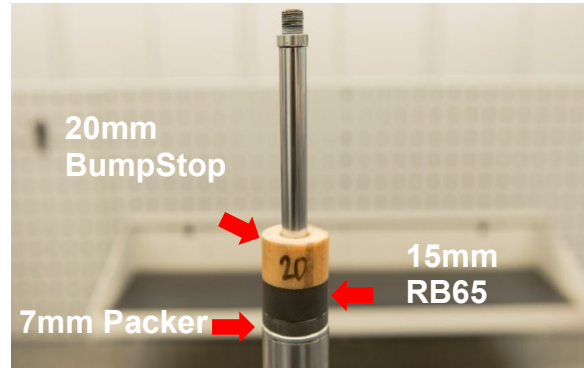

## 114. Bodywork

### 114.1. General description

- Lightweight bodywork with intelligent aluminium-steel composite construction
- Welded-in roll cage, in compliance with FIA Homologation Regulations for safety cages
- Front bonnet with quick release fasteners
- Rear deck with quick release fasteners
- Fixed carbon rear win side plates, black aluminium wing support with integrated gurney flap
- Modified Cayman GT4 cockpit: -Porsche Motorsport steering wheel, paddles shift, Motorsport central console with typical Porsche switch layout Crash protected, lightweight battery and optimised ECU position
- Six-point safety harness
- FIA certified towing loops
- Portable fire extinguisher
- Three-piston air jack
- 100 litre FT3 Safety cell with 'Fuel cut off' safety valve according to the FIA

### 114.2. External Bodywork (including Windows)

The windows of the Driver and passenger door, the rear side windows and the rear window must be covered with safety foil as described in the parts catalogue and the user manual.

The outside of the windscreen may also be covered with a clear safety film/rip-off film (not coloured). The laminated glass front windscreen may optionally be replaced by a polycarbonate windscreen.

MTHPN.: MTH541911

In general, it is not permitted to close or glue openings or joints. In the case of provisional repairs during the Event, joints or openings in the direct vicinity of the damage may be covered with adhesive tape if this is necessary due to a lack of time. The technical delegate will decide on whether the repairs are permissible.

### 114.3. Cockpit

No individual ventilation hoses are permitted. A drinks unit may be fitted if this is a permanent attachment, and the mounting points can withstand an acceleration of up to 25G. It is at the technical delegate's discretion to assess whether he believes the attachment used is sufficient. The pedals may not be changed. This does not include adding a film with increased friction. The seat, seat rails and belts must correspond to the parts catalogue. The series steering column adjustment mechanism is maintained. All covers in the cockpit must be used as described in the parts catalogue.

### 114.4. Seat, seat console Porsche Cayman GT4 CS (Type 981 and Type 982)

No.	Part No.	Description	Homologation No.
1	9915214298A	Seat console RECARO, Model 7308864	AS.027.12
2	9915212818A	Seat RECARO, Model P1300 GT	AS.027.12

Assy six point safety belt Porsche Cayman GT4 CS (Type 981)

No.	Part No.	Description	Homologation No.
1	98180301780	Gurt SCHROTH	FIA C-129.T/98 FIA D-130.T/98

Assy six point safety belt Porsche Cayman GT4 CS (Type 982)

No.	Part No.	Description	Homologation No.
1	98180301781	Gurt SCHROTH	SH.014.17-T-6

## 115. Additional Accessories

### 115.1. Underbody

In order to protect the front underbody and the underside of the luggage compartment, two metal skid blocks may be fitted to the Car underside as an option. These skid blocks have to be fitted on the surfaces left/right used for measuring the Car height at the front. MTHPN.: MTH804750

### 115.2. Engine cover:

It is allowed to install the engine cover: MTHPN.: MTH513411

### 115.3. Engine Air Ducts

To protect the two engine air ducts and the engine compartment ventilation system from sucking debris, the protection meshes into the air intakes in the body sills left and right is mandatory. MTHPN.: MTH541561 & MTH541562

### 115.4. Aerodynamic Devices

The specifications can be found in the parts catalogue, and these must be fitted unchanged. It is mandatory to close the openings (diffusor) at the front wheelhouse covers by separate covers.

MTHPN.: MTH504701 (diffusor left)

MTHPN.: MTH504702 (diffusor right)

MTHPN.: MTH512850 (gurney 22mm +1mm /-1mm)

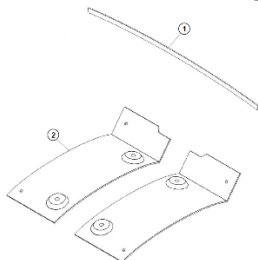

### 115.5. Safety nets:

It is mandatory to use the after sales safety nets as specified in the valid spare parts catalogue and mounted complying with the mounting instructions. MTHPN.: MTH801010 or MTH801005

#### 115.6. Driveshaft flange spacer:

Between the transmission and driveshaft flanges a 10mm spacers, together with bolts, must be installed.

MTHPN.:	MTH332527	(Spacer)
MTHPN.:	MTH332524	(Bolts M10x1,5x55, 12.9)

#### 116. Electrical Equipment

The Cayman GT4 Clubsport has a tyre pressure system (RDK) as a standard feature. It is mandatory to use the RDK sensors during the Event.

If the race organizer should require additional systems that result in data transfer, this must be approved by the technical delegate. Only the sensors described in the parts catalogue may be used.

Serial headlight Xenon (Specification series parts catalogue Cayman GT4)

Optional systems:

Additional lighting kit		MTHPN.:	MTH631200
Individual parts:	Main Harness	MTHPN.:	MTH631205
	Switch Wiring Harness	MTHPN.:	MTH631210
	Bulb Holder	MTHPN.:	MTH631215

Steering wheel operation kit MTHPN.: MTH347800  
The steering wheel control kit allows operating the radio, the hydration system, and hiding the auxiliary lighting from the steering wheel.

Individual parts:	Control Module	MTHPN.:	MTH347804
	Function Plate	MTHPN.:	MTH347805
	Main Harness	MTHPN.:	MTH347806

#### 117. Air Jack System

The air lifting system including the air lance system is mandatory. MTHPN.: MTH583004  
The positions of all the components that are relevant for the system, such as the air lance connector mounted on the Car, may not be changed.

In addition, regulations stipulate that, after the air lance is removed from the air lance connector, the pressure must remain in the lifting system. Only the operation of the valve mounted on the Car must lead to air being released and the jacks being pulled-in.

#### 118. Water-based paint:

- Exterior: white C9A
- Interior: white filler-coat, no clear-coat finish

#### 119. Overall Car dimensions and overhangs:

- The overall length of the Car is 4438mm, Total width: 1817 mm, Total height: 1,266 mm
- Wheelbase: 2,472 mm +/-15 mm

#### 120. Lubrication system

Engine:		FF100 Mobil 1 0W-40
Transmission:	Clutch oil (ATF):	Pentonsin FFI 3
	Final drive:	75 W 90 Mobilube PTX

The above mentioned oil types are mandatory. All additives are prohibited.

#### 121. Fuel system

A safety fuel tank according to FIA standard FT3-1999 by Art. 253.14 is installed. The maximum fuel volume of 100 litres is made up of the internal volume of all fuel-carrying components, including e.g. the filler pipe or the filler neck. Only the participant is responsible for ensuring that the maximum permitted volume is not exceeded. It is permitted to reduce the volume of the fuel tank using volume displacers/displacement balls. Three different refuelling systems are allowed. One of those three system must be installed. Only original parts specified in the Porsche Motorsport and/or Manthey Racing catalog can be used.

**121.1. 'Trophy' specifications (refuelling with fuel gun)**

This system developed for refuelling with fuel gun or dumping barrels. The tank refuelling plate for fuel gun use must be installed with the bonnet with rounded whole, finished with carbon fibre ring.

- 'Trophy' spec refuelling plate: MTHPN.: MTH201005
- Bonnet made of sheet metal, with round hole: MTHPN.: MTH511011

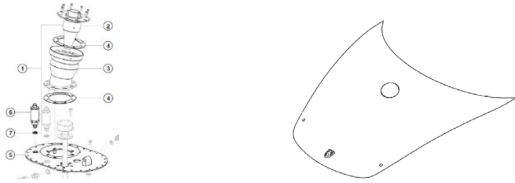

**121.2. Rollover valve:**

Mandatory rollover valve for all type 981 MTHPN.: MTH201705

